



# Heating Oil Tank Program

## Generic Remedy Guidance Document

(OAR Chapter 340 – Division 177  
and  
OAR 340-122-0252)

**Oregon DEQ - Northwest Region Office**  
**Heating Oil Tank Program**  
**1550 NW Eastman Parkway, Suite 290**  
**Gresham, OR 97030-3850**

For “Property Transaction”, “Expedite” or “Rush Only” Processing Of This File Please Use This Address:

State of Oregon  
Department of Environmental Quality  
Attention: HOT Program  
1550 NW Eastman Parkway Suite 290  
Gresham, OR 97030

For All Other Transactions Regarding This File Please Use This Address:

State of Oregon  
Department of Environmental Quality  
Attention – Accounts Receivable  
811 SW Sixth Avenue  
Portland, OR 97204

## Acknowledgements

This document, *Generic Remedy for Cleanup of Petroleum Contaminated Soil from Releases from Residential Underground Heating Oil Tanks*, was developed by the Heating Oil Tank Generic Remedy Workgroup. Members included:

Michael Anderson, DEQ, Waste Management Division

Ron Bergeson, Bergeson-Boese & Associates

Jim Glass, DEQ, Western Region UST Cleanup Program

Ron Goodman, Goodman Bros., Inc.

Laurie McCulloch, DEQ, UST Program

Mitch Scheel, DEQ, Northwest Region UST Cleanup Program

Karen White-Fallon, DEQ, Western Region UST Cleanup Program

Chris Wohlers, Wohlers Environmental Service, Inc.

Additional review was provided by managers and staff of the Underground Storage Tank (UST) program. Members of the public were invited to review and comment on the September 1, 1999 draft of this document. Comments were received from four interested parties. Their suggestions were considered and incorporated where appropriate into this final document.

Background technical documentation for this Generic Remedy is contained in a separate report *Developing Risk-Based Standards for Residential Heating Oil Tanks // Heating Oil Tank Generic Remedy Addendum – Generic Risk Assessment Documentation, September 1999*.

## Approval

This guidance document has been approved for use by the Oregon Department of Environmental Quality Land Quality Division.

<signed by>  
Mary Wahl, Division Administrator

January 24, 2000  
Original Date Approved

**Generic Remedy for Cleanup of Petroleum Contaminated Soil  
from Releases from  
Residential Underground Heating Oil Tanks**

**Table of Contents**

| <b>Topic</b>   | <b>Page<br/>Number(s)</b> |
|--|---------------------------|
| Background Information.....  | 4 - 5                     |
| Steps for Using this Guidance Document - Section 1.....                                  | 6                         |
| Qualifying Criteria for Generic Remedy - Section 2.....                                  | 7 - 8                     |
| Cleanup Alternatives - Section 3.....  | 9 - 10                    |
| Site Assessment - Section 4.....   | 11 - 17                   |
| Written Report Requirements - Section 5.....   | 18                        |
| List of Appendices - Section 6.....  | 18                        |
| ▪ Appendix 1 Locating the Tank.....  | 19                        |
| ▪ Appendix 2 Decommissioning the Tank.....   | 20 - 24                   |
| ▪ Appendix 3 Sampling and Analysis - Excerpts from<br>OAR Chapter 340, Division 122..... | 25 - 29                   |
| ▪ Appendix 4 Contact Information for DEQ Regional<br>Offices.....                        | 30 - 31                   |
| ▪ Appendix 5 Blank Forms for Optional Use.....   | 32                        |

## Background Information

Oregon Administrative Rule (OAR) 340-122-0252, adopted in November, 1998, allows for the development and use of a generic remedy for the cleanup of common categories of contaminated sites. The rapid increase in the number of releases reported from residential heating oil tanks over the last several years has made this category of sites an excellent candidate for development of a generic remedy guidance document.

A generic remedy that includes risk-based concentrations must be based on a generic risk assessment that documents the Department's conclusions, with respect to how sites eligible for use of the generic remedy will achieve acceptable risk levels. This documentation is provided in a separate report titled *Developing Risk-Based Standards for Residential Heating Oil Tank Sites // Heating Oil Tank Generic Remedy Addendum – Generic Risk Assessment Technical Documentation, September 1999*. This document is available from the Department upon request by calling 1-800-742-7878 (in Oregon) or 503-667-8414 ext 55026. Or you may view and download the document at our web site at <http://www.deq.state.or.us/lq/tanks/hot/index.htm>.

This guidance provides a streamlined approach to site characterization and cleanup of heating oil contamination by prescribing generic risk-based concentration levels and is designed for sites that meet the qualifying criteria outlined in Section 1. Some anticipated benefits of this generic remedy are:

- Cost savings for homeowners for analytical costs and/or contaminated soil removal expenses.
- Faster and easier report preparation by service providers and more efficient reviews by the Department.
- Less contaminated soil moved from one location to another resulting in pollution prevention activities such as avoiding transfer of volatile pollutants from soil to the air.

This document has been developed to provide specific guidance on site investigation and remedial action activities *as they are related to implementing this generic remedy for heating oil releases*. It is not intended to be general guidance on site investigations, risk assessments, compliance sampling, or other related activities. Additional guidance may be needed to ensure that all phases of the project have been completed in a manner acceptable to the Department.

Assumptions made in the development of this document were based on experience with typical heating oil-contaminated sites where diesel #2 was the contaminant. The Department may modify this guidance document as new information becomes available.

## **Additional Information**

The generic risk assessment and resulting risk-based concentration levels found in this document are based solely upon potential risk to human health. Implementation of this guidance is based on the assumption that there are no unacceptable ecological risks from the heating oil found at the site. The Qualifying Criteria in Section 1 were developed with this limitation in mind. Should potential ecological risks be present at a specific site, further assessment of this potential risk will be required and use of this Generic Remedy may not be applicable.

This document does not supersede other applicable federal, state or local regulations, including but not limited to those specified in:

- OAR Chapter 340, Division 177  
- Residential Heating Oil Underground Storage Tanks
- OAR Chapter 340, Division 122  
- Cleanup Rules for Leaking Petroleum UST Systems

Note: Soil analytical test methods for Total Petroleum Hydrocarbons (TPH) are expressed in the units “ppm” (parts per million) and “mg/kg” (milligrams per kilogram). These units are equivalent, and used interchangeably throughout this document.

## **Definitions**

As used in this document:

The term “contaminated soil” means any heating oil impacted soil where TPH concentrations exceed 50 mg/kg NWTPH-Dx.

The term “seasonal high groundwater level” means the shallowest depth from the ground surface to the water table experienced in a typical year. This can vary considerably based on which area of the state the site is located. In the wetter parts of the state this would typically be measured during the winter or spring when soils have been saturated from months of rain. In dryer parts of the state, groundwater levels may not fluctuate significantly during the year.

## Section 1. Steps For Using The Heating Oil Tank Generic Remedy Guidance

The following flow chart provides the step-by-step procedures required for the selection and implementation of this generic remedy guidance.

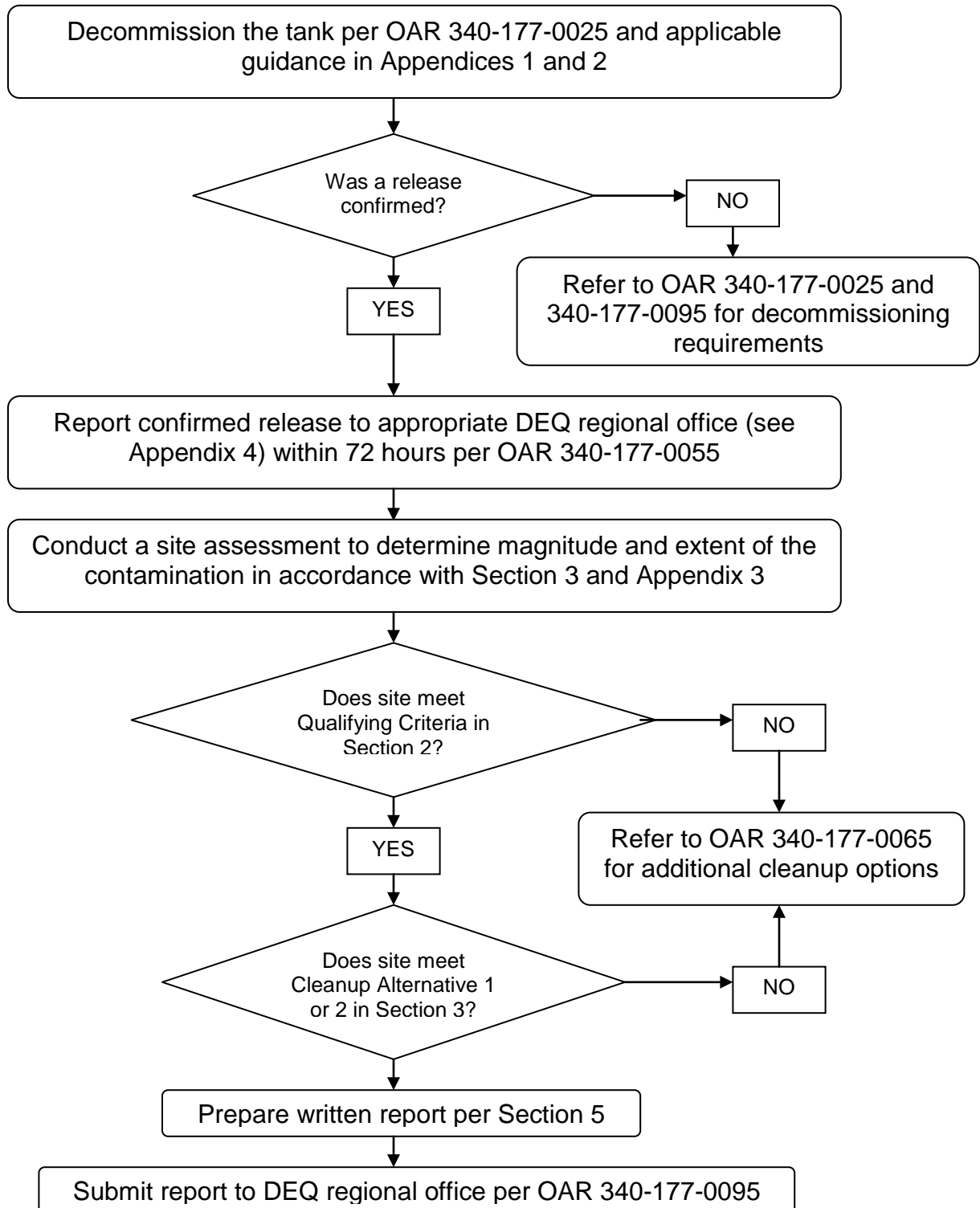

## Section 2. Qualifying Criteria

In order to apply this generic remedy to a heating oil contaminated site, all of the following criteria must be met:

◆ **The release is from an underground heating oil tank.**

While this generic remedy was developed for use on residential properties, it may be applicable to commercial heating oil tank sites if all other conditions are met (you should contact a DEQ regional UST staff for guidance prior to applying the generic remedy to a commercial site);

◆ **The only petroleum product that has been released at the site is heating oil (diesel #2).**

There should be no gasoline, solvents, used oil, or other petroleum products being cleaned up under this generic remedy.

◆ **Contamination is limited to soil only with no groundwater detected in the tank cavity or in any soil borings.**

◆ **No free product is present as a result of the tank leak.**

◆ **There are no ecological risks posed by the release.**

**All of these criteria must be met for a site to be eligible for assessment and/or cleanup under this generic remedy.**

**If the cleanup site does not meet these criteria, refer to OAR 340-177-0065 for other cleanup options available.**

## Section 2.2 Diagram

The following diagram depicts the conceptual site model for a generic heating oil tank site. The reference to the size of the home (1200 sq. ft. or larger) is important as it pertains to calculations made in the generic risk assessment. Some recalculations may be necessary if the home is very small and vapor intrusion into the home from contaminated soil is likely.

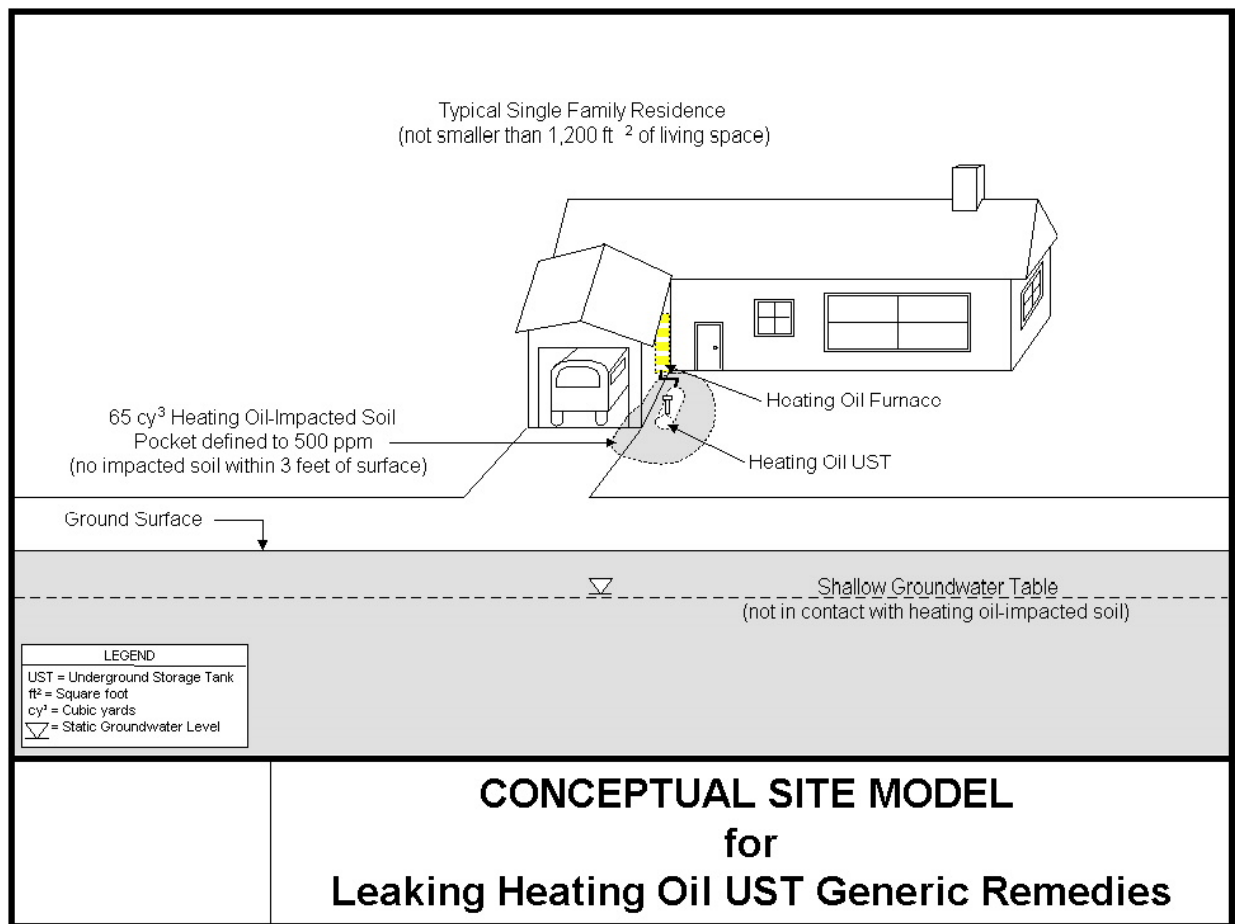

### **Section 3. Cleanup Alternatives**

Once it has been determined that the site meets the Qualifying Criteria in Section 2, the next step is to determine if the site meets the one of the generic remedy cleanup alternatives. For each alternative, the extent of the contamination must first be delineated to a TPH concentration equal to, or less than, 500 ppm by Method NWTPH-Dx (DEQ, December, 1996).

#### **Cleanup Alternative 1**

Each of the following elements must be met for this alternative to be appropriate.

- ◆ The maximum level of TPH contamination remaining in residual soil is less than or equal to 2,500 ppm.
- ◆ The volume of residual soil with TPH contamination levels equal to or more than 500 ppm does not exceed 65 cubic yards.
- ◆ There is at least three (3) feet of non-contaminated soil above any contaminated soil remaining at the site.
- ◆ Contaminated soil remaining at the site is above the seasonal high groundwater level.

#### **Additional Notes:**

- This alternative may apply to sites where the tank has been decommissioned either in-place or by removal.
- Under this alternative, contaminated soil removal may be used to meet the protective level of 2,500 ppm TPH. The decision to remove contaminated soil to comply with Alternative 1, or to proceed with Alternative 2, should be made by the homeowner based on cost or other personal preferences in consultation with the licensed service provider.

If site conditions are not appropriate for use of this alternative, the next step is to determine if Cleanup Alternative 2 is appropriate.

**IMPORTANT:** Any contaminated soil excavated and removed from the site must be disposed of in a Department approved landfill or treatment facility. Stockpiled petroleum contaminated soil cannot remain on-site for a period exceeding thirty days unless otherwise approved by the Department. At all times, contaminated soil stockpiled on the site awaiting disposal or treatment must be kept within a secure area and adequately covered and bermed.

## **Cleanup Alternative 2**

Each of the following elements must be met for this alternative to be appropriate.

- ◆ The maximum level of TPH contamination remaining in residual soil is less than or equal to 10,000 ppm.
- ◆ Analysis for the presence of benzene, ethylbenzene and naphthalene must be performed on all samples exceeding 2,500 ppm TPH. Measured concentrations for ethylbenzene and naphthalene in soil cannot exceed the generic risk-based concentrations in effect at the time of the cleanup project. Benzene concentrations cannot exceed 0.1 ppm.
- ◆ The volume of residual soil with TPH contamination levels equal to or more than 500 ppm does not exceed 65 cubic yards.
- ◆ There is at least three (3) feet of non-contaminated soil above any contaminated soil remaining at the site.
- ◆ Contaminated soil remaining at the site is above the seasonal high groundwater level.

### **Additional Notes:**

- Additional soil removal may be conducted and sampling repeated to meet this alternative. Again, this is a decision the homeowner should make based on cost or other personal preferences in consultation with the licensed service provider.
- Under this alternative the Department will also require an estimation of the distance from the source of the contamination and any surface water feature within 100 feet.
- The protective levels (Risk Based Concentrations) referenced in this generic remedy, and the soil constituent of concern (benzene), along with the exposure pathways of concern (i.e. vapor intrusion into buildings and leaching to groundwater), are described in detail in the document *Heating Oil Tank Generic Remedy Addendum – Generic Risk Assessment Technical Documentation, September 1999*.

**If site conditions do not meet either of the alternatives above, use of this generic remedy for heating oil cleanups is not allowed.**

**Refer to OAR 340-177-0065 for other cleanup options available.**

## **Section 4. Site Assessment**

A site assessment must be made to determine the source, nature, magnitude, and extent of the contamination associated with a release from an underground heating oil tank. This is necessary for the purpose of applying this generic remedy. The site assessment must gather sufficient information to demonstrate that the site meets:

- the qualifying criteria outlined in Section 2, and
- the requirements for cleanup alternatives described in Section 3

For these reasons, the site assessment must specifically address the following:

- ◆ An assessment for the presence of free product
- ◆ An assessment to determine if groundwater is impacted and the depth to groundwater
- ◆ The vertical and horizontal extent of heating oil contamination

### **Section 4.1 Free Product Assessment**

Determining the presence of free fuel product is very simple. If there is a pool(s) of liquid fuel in the tank excavation, or clearly visible saturated soil, free product is present and use of this generic remedy is not allowed.

If the free product is a direct result of a spill that occurred during the immediate tank decommissioning work, this is not considered to be free product for the purpose of determining if the generic remedy is appropriate for use. The spilled fuel must be immediately removed from the excavation to avoid spreading the contamination.

Note: If any fire or safety hazards are posed by vapors or free product, the appropriate DEQ regional office must be notified immediately.

### **Section 4.2 Groundwater Assessment**

*Groundwater Impact:* To determine whether water encountered in the tank excavation is groundwater, pump the water from the pit and dispose of it in accordance with all currently applicable requirements. This may require obtaining permits from the Department or local jurisdictions. If the pit remains dry for 24 hours, sampling and cleanup may proceed under the generic remedy. If water returns in less than 24 hours, it is presumed to be groundwater and the use of this generic remedy is not allowed.

Note: If groundwater is encountered at any time during release identification or cleanup, the appropriate DEQ regional office must be notified immediately.

*Depth to Groundwater:* If the depth to groundwater is not determined with an on-site excavation or soil boring, this information can typically be obtained from the owner of a nearby shallow well, from a local well drilling company, or the county Water Master. In addition, the Oregon Water Resources Department may be able to provide information on area wells through their office or on-line information system.

### **Section 4.3 Magnitude and Extent of Contamination**

The requirements for determining the vertical and horizontal extent of contamination will vary depending on the magnitude of the contamination and/or the method used to decommission the tank. The minimum site assessment requirements for the purpose of this generic remedy are:

#### **If the tank is removed during decommissioning:**

Collect two soil samples, one from each end of the excavation. Each sample must be collected at least six inches below the bottom of the excavation, but no more than one foot below the bottom of the former heating oil tank. If there are obvious areas of contamination based on visual observations or odors, samples must be collected from these areas of contamination as well.

#### **If the tank is decommissioned in-place:**

Collect two soil samples, one from each end of the tank, no more than six inches from the ends of the tank, unless otherwise approved by the Department. Each sample must be collected at least one foot, but no more than two feet, below the bottom of tank. If there are obvious areas of contamination based on visual observations or odors, samples must be collected from these areas of contamination as well.

#### **Additional notes:**

- The soil samples must be collected in accordance with OAR 340-122-0340 and 340-122-0345 and analyzed for Diesel/Lube Oil Range Hydrocarbons by Method NWTPH-Dx (DEQ, December, 1996) in accordance with OAR 340-122-0218, as required by OAR Chapter 340, Division 177. Refer to Appendix 3 for additional details.
- Multiple samples will need to be collected after contaminated soil removal to determine the magnitude of the remaining contamination. Again, the extent of the contamination must be delineated to a TPH concentration equal to or less than 500 ppm.

## Section 4.4 Minimum Delineation Requirements

In accordance with the Cleanup Alternatives outlined in Section 3, an estimate of the volume of contaminated soil proposed to remain at the site will be required to ensure that the 65 cubic yard limitation is not exceeded. The results of soil samples analyzed for the presence of heating oil (TPH-Dx) are required to determine both the vertical and horizontal extent of contamination remaining above 500 ppm.

If soil samples cannot be retrieved because of extreme site conditions, (e.g. cobbles or boulders present at the site results in auger refusal) a mathematical rate of contamination reduction estimate may be substituted in lieu of soil sample analytical results to determine the vertical and/or the horizontal extent of the contamination remaining above 500 ppm. The following is a brief description of one acceptable method.

After the concentrations in soil beneath the tank have been determined as outlined in Section 4.3, additional soil samples should be collected a set distance (i.e. 3 to 5 feet) away. Care should be taken to accurately record the vertical and horizontal distance from the initial sampling point as this information will be needed to develop a rate of contaminant reduction. The goal in selecting your sampling points should be to document levels of reduced contamination rather than an area of no detection. Collecting samples from a location too far away will typically result in over-estimating the remaining volume of contaminated soil.

The following simple formula can be used to determine the rate of contamination reduction:

$$R = A_1 - A_2 / D$$

Where: **A<sub>1</sub>** = Initial sampling point analytical result  
**A<sub>2</sub>** = Additional delineation sampling point analytical result (**A<sub>2</sub> < A<sub>1</sub>**)  
**D** = Distance between A<sub>1</sub> & A<sub>2</sub>  
**R** = Rate of contamination reduction

The next two pages are examples of this formula. Note that the example diagrams include the specific sample point (location) data used in the example formula at the bottom of each page.

Refer to Appendix 5 for example forms for cleanup alternatives 1 and 2. These are blank forms intended to be used as worksheets to “fill in” real sample results from a heating oil cleanup site as needed.

## EXAMPLE OF DELINEATION SAMPLING ALTERNATIVE 1

LESS THAN OR EQUAL  
TO 2,500 PPM

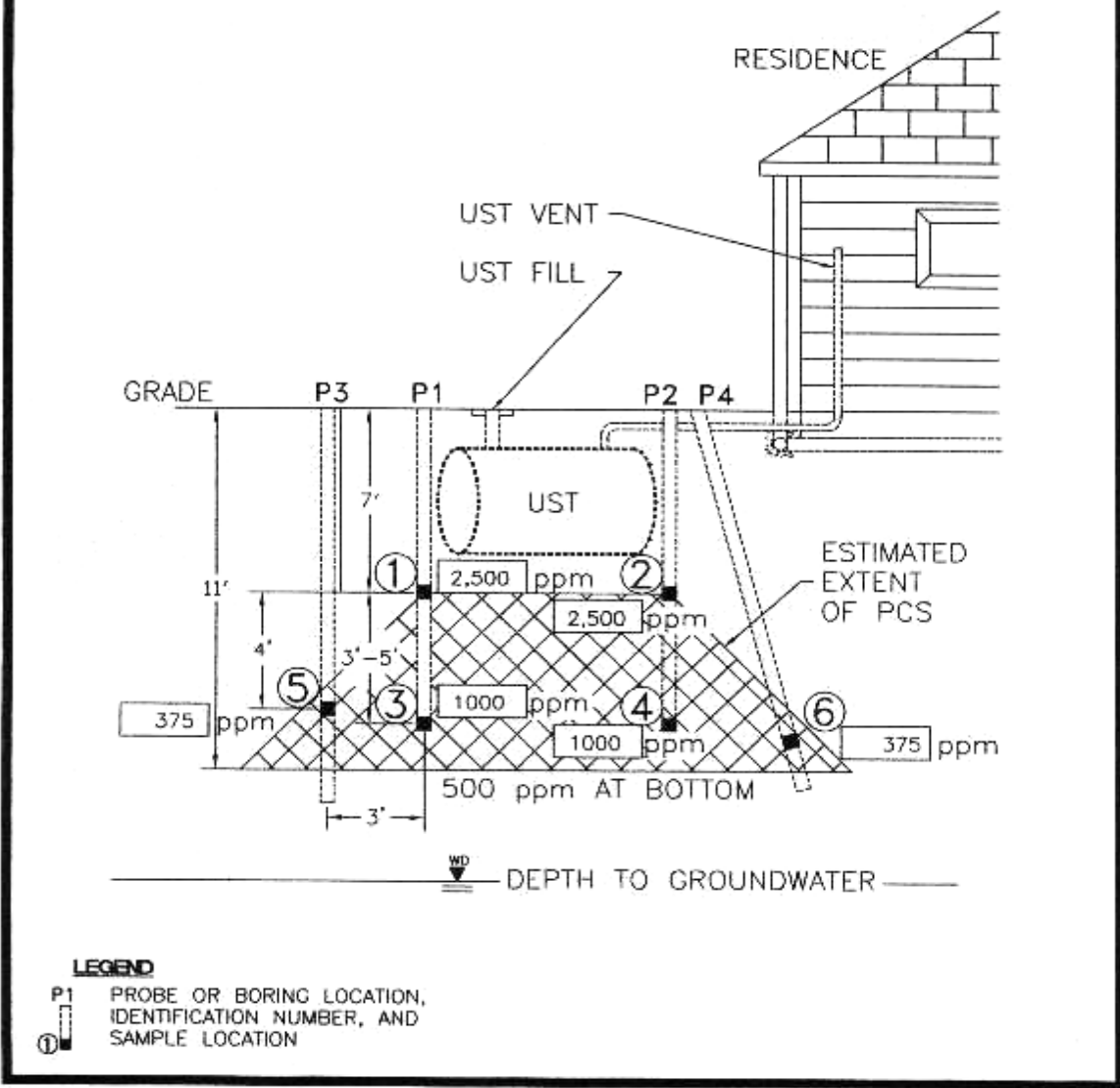

$$A_1 = \text{Sample location P1.1} = 2,500 \text{ ppm TPH} \quad A_2 = \text{P1.3} = 1,000 \text{ ppm} \quad D = 3 \text{ feet}$$

$$R = \frac{(2,500 - 1,000)}{3 \text{ ft.}} = \frac{1,500}{3 \text{ ft.}} = \frac{500}{1 \text{ ft.}}$$

Therefore the vertical TPH contamination reduction rate is equal to 500 ppm per foot.

## EXAMPLE OF DELINEATION SAMPLING ALTERNATIVE 2

GREATER THAN 2,500 AND  
LESS THAN 10,000

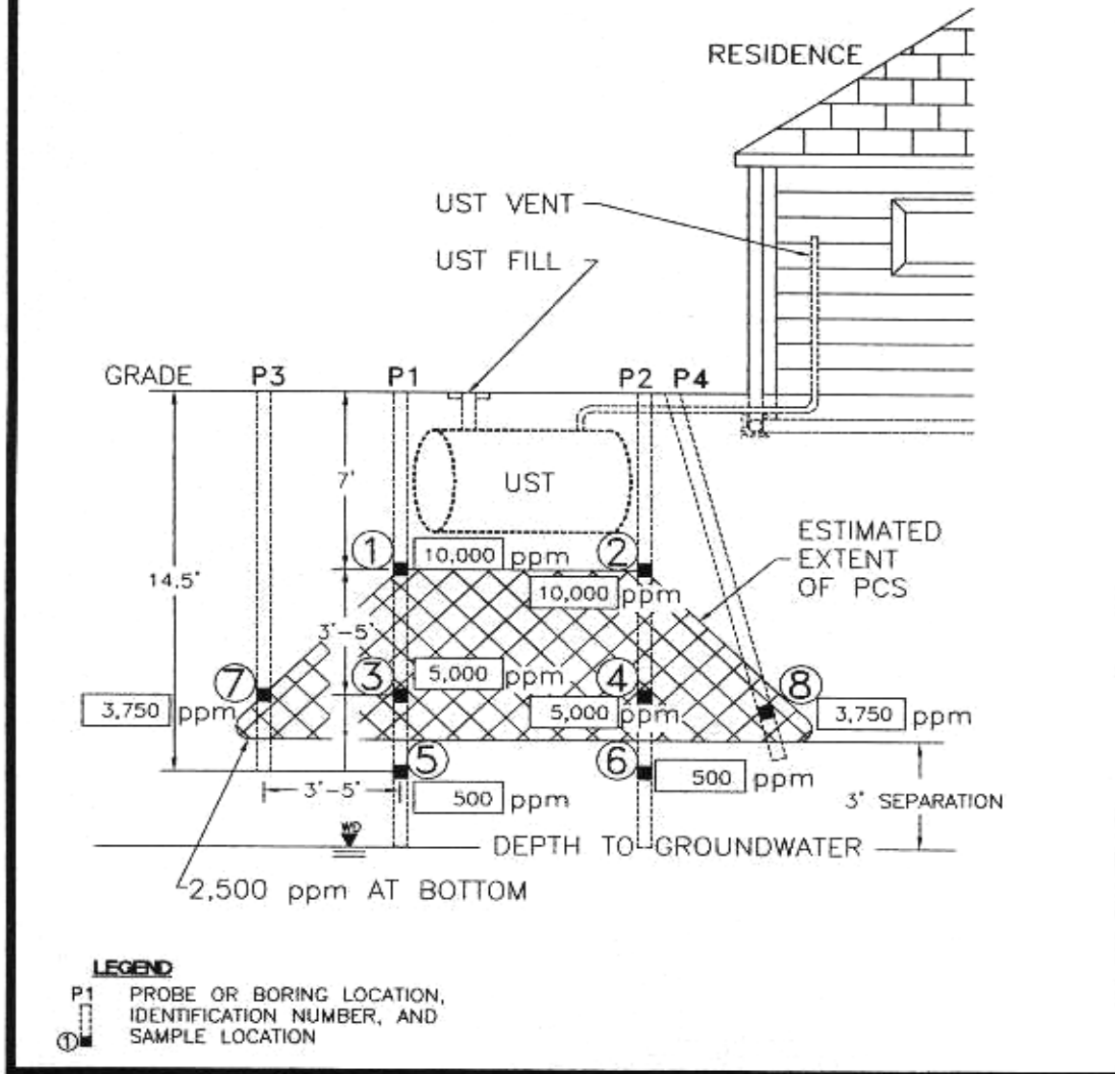

$$A_1 = \text{Sample location P1.1} = 10,000 \text{ ppm TPH} \quad A_2 = \text{P1.3} = 5,000 \text{ ppm} \quad D = 4 \text{ feet}$$

$$R = \frac{(10,000 - 5,000)}{4 \text{ ft.}} = \frac{5,000}{4 \text{ ft.}} = \underline{1,250} \text{ ppm per foot}$$

Therefore the vertical TPH contamination reduction rate is equal to 1,250 ppm per foot.

This rate of contamination reduction can now be used to estimate the volume of contaminated soil that exceeds 500 ppm (as TPH-Dx) remaining at your specific site.

*Example No. 1:* Using the same numbers from the first example, the Total Estimated Distance to the 500 ppm TPH limit is 4 feet [3 feet Distance (**D**) between delineation sampling points plus 1 foot Estimated Distance (**ED**) based on the reduction rate].

$$A_2 = 1,000 \text{ ppm} \quad B = 500 \text{ ppm} \quad D = 3 \text{ feet} \quad R = \frac{500 \text{ ppm}}{1 \text{ ft.}}$$

(desired analytical result)

$$\text{(Estimated Distance) } ED = \frac{(A_2 - B)}{R} \text{ (delineation end point concentration)}$$

$$ED = \frac{(1,000 \text{ ppm} - 500 \text{ ppm})}{500 \text{ ppm / foot}} = 1 \text{ foot}$$

Total Estimated Vertical Distance to 500 ppm TPH = **D** (3 ft) + **ED** (1 ft) = 4 feet

*Example No. 2:* Using the same numbers from the second example, the Total Estimated Distance to the 500 ppm TPH limit is 7.6 feet [4 feet Distance (**D**) between delineation sampling points plus 3.6 feet Estimated Distance (**ED**) based on the reduction rate].

$$A_2 = 5,000 \text{ ppm} \quad B = 500 \text{ ppm} \quad D = 4 \text{ feet} \quad R = \frac{1,250 \text{ ppm}}{1 \text{ ft.}}$$

(desired analytical result)

$$\text{(Estimated Distance) } ED = \frac{(A - B)}{R} \text{ (delineation end point concentration)}$$

$$ED = \frac{(5,000 \text{ ppm} - 500 \text{ ppm})}{1,250 \text{ ppm / foot}} = \frac{4,500 \text{ ppm}}{1,250 \text{ ppm / foot}} = 3.6 \text{ feet}$$

Total Estimated Vertical Distance to 500 ppm TPH = **D** (4 ft) + **ED** (3.6 ft) = 7.6 feet

These simple equations can be used to estimate both the vertical and horizontal extent of contamination. [Note: The examples above depict vertical extent only - additional samples and similar calculations may be required to determine the horizontal extent.] With this information in hand there are a few simple formulas that can be employed to calculate the total estimated yardage of contaminated soil remaining at the site.

The following is an example of one acceptable formula.

Assuming symmetrical horizontal migration approximated by a section of a right circular cone with the top and bottom radii determined from site specific sampling results, observations made during the investigation, and/or from the process outlined above:

Section of a cone where:

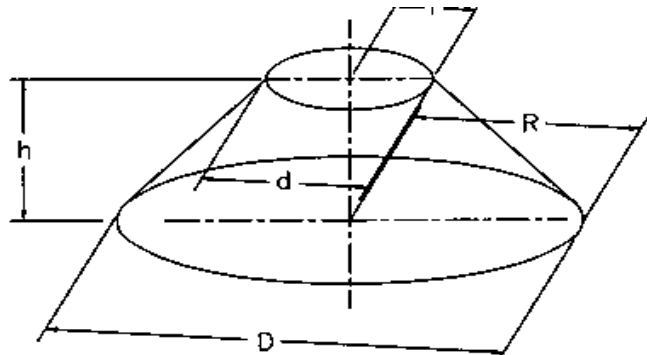

|                  |       |    |                  |       |
|------------------|-------|----|------------------|-------|
| Vertical extent, | $h_L$ | OR | Vertical extent, | $h_L$ |
| Top radius,      | $r$   |    | Top diameter,    | $d$   |
| Bottom radius,   | $R$   |    | Bottom diameter, | $D$   |

$$\text{Volume} = 3.14/3 \times h_L (R^2 + Rr + r^2) \quad \text{or} \quad V = 3.14/12 \times h_L (D^2 + Dd + d^2)$$

For example: assuming top radius of 4 feet and bottom radius of 12 feet and lens thickness of 7.5 feet.  $(3.14/3) \times 7.5 [12.0^2 + (12 \times 4) + 4.0^2] = 1633.5$  cubic feet.

To obtain a cubic yardage equivalent, divide the cubic feet estimation by 27 (i.e.  $1633.5 / 27 = 60.5$  cubic yards). Keep in mind that you will need to determine and subtract the size (volume) of your remedial excavation, if one is made.

If the remaining contamination remains only on one end of your tank or, if you have removed contamination on all but one side of your excavation, you may find that estimating the entire radius is not needed. In this case it is also acceptable to estimate the volume for one side using the formula for a right-angle triangle:  $V = \frac{1}{2} (h_L \times w_L \times L_L)$ .

|                      |       |
|----------------------|-------|
| Right-Angle Triangle |       |
| Vertical extent,     | $h_L$ |
| Horizontal extent,   | $w_L$ |
| Length               | $L_L$ |

## **Section 5. Written Report Requirements**

Written reports describing actions taken as part of a heating oil tank cleanup are required in accordance with OAR 340-177-0055 and 340-177-0095. The reports can either be narrative or on a form prepared by the Department.

A report form with instructions has been prepared for the heating oil tank Generic Remedy cleanup option. Both are reproduced in Appendix 5 and can be copied directly from this manual. Or, you can obtain clean forms by:

Accessing the DEQ HOT Program Web Page at  
**<http://www.deq.state.or.us/lq/tanks/hot/index.htm>**

Calling the DEQ UST HELPLINE at 1-800-742-7878 inside Oregon (recorder)

Calling 503-667-8414 ext 55026

Calling one of the DEQ Regional Offices listed in Appendix 4.

In all cases, please read the instructions before completing the forms.

## **Section 6. Appendices**

The use of multiple appendices is intended to provide additional guidance in performing activities necessary for implementation of this guidance document. Additional references may be included within the individual appendices.

Appendix 1 Locating the Tank

Appendix 2 Decommissioning the Tank

Appendix 3 Sampling and Analysis - Excerpts from OAR Chapter 340, Division 122

Appendix 4 Contact Information for DEQ Regional Offices

Appendix 5 Blank Forms for Optional Use

## **Appendix 1            Locating the Tank**

Heating oil USTs are generally located within two feet of the structure they serve and will be buried approximately two feet below land surface. Most heating oil tanks are 46 inches in diameter and vary in length from four feet (340 gallon) to eight feet (675 gallon). The tanks are usually in a location convenient for filling, and close to where the furnace is located within the home.

Although it can vary from home to home, the following outlines some general steps in locating the tank.

### **STEP 1            Locate The Fill Pipe or Vent Pipe**

The best way to locate a buried tank is to first locate the fill pipe or the vent pipe. The fill pipe will generally be close to the ground and often marked so the delivery person can quickly and easily identify it. However, when a fuel tank has been abandoned for some time, it is common for the fill pipe to become obscured with grass, dirt, plants, etc.

If you can't locate the fill pipe, the vent pipe will almost always be visible. The vent pipe will be approximately 1.25 – 1.5 inches in diameter and is usually visible up the side of the house. The vent will extend above ground approximately two to eight feet and should have a small vent cap on it.

### **STEP 2            Locate the Tank**

Once either the fill or vent pipe has been identified, the tank can be located by digging along the pipe to the tank. You may need to dig down about two feet, but the fill and vent pipes are usually less than 5 to 10 feet from the tank.

In some cases, it may be helpful to use a small metal rod to push into the ground in the area where you suspect the tank is located. If you do this, be very careful not to push the rod hard enough that it punctures the tank.

## Appendix 2            Decommissioning the Tank

There is no document that can replace appropriate knowledge, experience, and training in proper tank decommissioning practices. Decommissioning regulations are contained in OAR 340-177-0025 and must be followed. This section provides additional guidance, but is not a substitute for the regulatory requirements.

Extreme care should be used during the decommissioning of underground heating oil tanks to reduce risks to human health, safety, and the environment.

### WHY DECOMMISSION HEATING OIL TANKS?

Underground heating oil tanks are a potential source of contamination of the soil and groundwater and may pose a fire and explosion hazard under certain conditions. Underground tanks also corrode and over time they may weaken to the point where they may collapse. Tanks should be decommissioned whenever they are no longer used or whenever there are questions about their structural integrity or their ability to hold product without leaking.

**Note:** Some local fire, planning, and building departments may have notification and permitting requirements. Be sure to contact them prior to beginning work to determine if any local requirements apply to your property or tank. It is also essential to contact your local utility company(s) to insure there are no buried lines in the vicinity of the underground tank.

### SAFETY PRECAUTIONS

Accidents from fire, explosion, excavation cave-in, and other hazards can occur during tank decommissioning. DEQ recommends following the procedures described in this document or in the references listed in the final section of this document to prevent such accidents and to protect life and property.

All persons doing tank decommissioning work should know and adhere to all applicable environmental, fire, health, and safety rules, regulations and practices; proper procedures for operating equipment and for freeing tanks of vapors and testing for combustible vapors, and the proper handling and disposal of wastes likely to be encountered.

The following safety and health hazards are of particular concern:

**Open Flames and Sparks** - Open flames, including oxygen/acetylene torches, matches, cigar and cigarette lighters, candles, burning tobacco, etc., should not be present near any tank or tank excavation. Electrical switches, equipment and electrical motors used near any tank or tank excavation should meet the explosion proof requirement of the National Electrical Code.

**Static Electricity** - Electrically ground all tools, piping, and electrical equipment used in the vicinity of underground tanks to prevent ignition of petroleum vapors by static electricity.

**Exposure to Petroleum Products** - Care should be exercised to minimize exposure to petroleum products such as heating oil as well as soil and water contaminated with these products. Avoid inhaling heating oil vapors and exposing skin to direct contact with heating oil when decommissioning these tanks.

## **PERMANENT DECOMMISSIONING OF HEATING OIL TANKS**

### **Decommissioning by Tank Removal**

1. Obtain the necessary local permits. Contact your local fire, planning, and building departments for information on local requirements and local utility company(s) to identify buried lines.
2. Drain and flush all piping into the tank, being careful to avoid spilling.
3. Remove all liquid from the tank, even liquid requiring a hand pump to remove. Remove any solids or sludge. Any material which cannot be recycled must be disposed of in accordance with applicable federal and state laws. Contact the local solid waste disposal facility to get recommendations for disposal options.
4. Carefully dig down to the top of the tank. Note any potentially contaminated soils and separate them from clean soils. Contaminated soils must be disposed of according to applicable state and local regulations. Look under "Environmental" in yellow pages of phone book or contact your local landfill for information.
5. Remove the product lines and other tank fixtures up to the building foundation then flush the remaining pipe and permanently cap the pipe ends.
6. Cap or remove any non-product lines, leaving the vent line open until after the tank is purged of vapor (i.e. inerted). Temporarily close off all openings in the tank except the vent line so that all vapors can be purged or so that oxygen may be displaced during the inerting process.
7. Inert or render vapor free all tanks containing combustible and flammable liquids, using **ONE** of the methods described below. Refer to API 1604 for detailed guidance.
  - A. Inert the tank with dry ice (1.5 pounds per 100 gallons of tank capacity). The dry ice should be evenly distributed over the whole area of the tank bottom and allowed to completely evaporate prior to working on the tank. During the inerting process, necessary precautions must be taken to prevent ignitions throughout the entire area that might be affected by the vapors.
  - B. Ventilate the tank with air using an eductor-type air mover. Such a device usually uses compressed air to cause the vapors to be drawn out of the tank. Discharge the vapors a minimum of 12 feet above the ground surface using an eductor extension.
  - C. Ventilate the tank with air, using a diffused air blower. The air pressure must not exceed 5 psig (pounds per square inch gauge). Install a 5 psig relief valve on the tank to prevent rupturing from overpressure.

- D. Inert the tank with a non-reactive gas, such as carbon dioxide or nitrogen. Again the internal tank pressure should not exceed 5 psig.
8. Monitor the vapor concentration levels in the tank and in the excavation area using a combustible gas indicator that has been maintained and calibrated according to the manufacturer's instructions. Once the indicator shows levels below 20 percent of the Lower Explosive Limit (LEL), the tank is considered inerted and safe for removal.
  9. Plug or cap all holes leaving an 1/8 inch vent hole to prevent differential pressures from building up due to temperature differences.
  10. Complete the excavation and remove the tank. As a safety precaution the tank should be blocked with wood blocks to prevent the tank from moving after it is removed.
  11. If there are no indications of heating oil contamination and no water is present in the tank pit, collect two soil samples from native soils in the area beneath the tank. If there is evidence of contamination such as petroleum odors or staining of the soil, soil samples must be collected from each distinct area where contamination is observed. Refer to Appendix 4 for more detail about sampling and analysis requirements. If heating oil contamination is detected in any of the soil samples at a concentration greater than, or equal to 50 mg/kg, a release has occurred. All releases must be reported to DEQ within 72 hours of discovery. Refer to Appendix 6 for the regional phone number to report releases. Investigation and cleanup may be necessary if contamination is detected in the soil samples so it may be advisable to delay backfilling the excavation until after reviewing the sampling results. Refer to Appendix 3 for site investigation information if contamination is found.
  12. When transporting, secure the tank on the truck so that the 1/8 inch vent hole is located at the highest point on the tank.

### **Decommissioning in Place**

Follow the same procedures described in Steps 1 through 8 in the section above entitled "Decommissioning by Tank Removal", then:

9. The tank and associated piping must be cleaned as thoroughly as possible to the maximum extent practicable of all product, sludge and/or water residue. This material must be recycled or disposed of in accordance with all local, state, and federal requirements.
10. Fill the tank with a non-reactive solid material, such as:
  - A. SAND: Sand that is free from rocks is suitable for filling. Open the top of the tank so that the tank can be filled completely. Fill the tank to nearly full and wash sand into the tank with a small amount of water, puddled to cause the sand to flow to the tank ends. Avoid using large amounts of water.

- B. SAND AND EARTH: Fill the tank with sand to nearly 80 percent of its capacity and fill the remaining capacity using a mixture of soil and water in a free-flowing mud.
  - C. PEA GRAVEL: Fill the tank to capacity with pea gravel.
  - D. CONCRETE SLURRY MIX: Fill the tank with concrete slurry mix. Add a wetting agent to the mixed concrete to reduce separation of the water from the sand and gravel.
11. Plug or cap all openings in the tank, including the vent line.

## **DISPOSAL OF TANKS, PIPING AND EQUIPMENT**

Recycling of tanks, piping and other UST system equipment as scrap metal is the preferred method for disposal of steel tanks that contained heating oil. Contact your local scrap metal dealer for more information. Landfill disposal of this material is also an acceptable alternative. Contact individual landfill disposal sites for their acceptance requirements. Reuse of the tanks for any purpose is not advised; contact the appropriate DEQ Regional Office if you have questions on tank reuse.

## **TRANSPORTATION OF TANKS**

Transport tanks from the site as soon as possible after they have been inerted and removed from the ground. Prior to transporting, check the atmosphere in all tanks using a combustible gas indicator to ensure that it is still below the lower explosive limit. Secure tanks on trucks with the 1/8-inch vent hole at the highest point on the tank. Transport tanks in accordance with all applicable local, state, and federal regulations. Check with local building, zoning, fire and highway departments prior to moving tanks from a site.

## **STORAGE OF USED TANKS**

Prior to storage, check the tank atmosphere using a combustible gas indicator to ensure that it is below the lower explosive limit. Block the tank to prevent movement with the 1/8-inch vent hole at the highest point. Alternatively, cut the tank in half or open one end to prevent the build up of combustible or explosive vapors within the tank. Used petroleum tanks should be treated as if they contain explosive vapors at all times. Check used petroleum tanks with a combustible gas indicator before doing any work on them. Storage of used tanks at a residential site is not recommended due to potential safety hazards.

## **RECORD KEEPING**

The property owner should document and retain permanent records of all decommissioning and cleanup activities including the names of companies performing work related to the tanks, the disposal methods and locations for all liquids, sludges and UST system components such as tanks, piping and other associated equipment. Permanent records should also include the following:

- a. Photographs of the tank decommissioning;
- b. Results of all soil analyses and engineering studies;
- c. Paid invoices/billings;
- d. Site maps or diagrams;
- e. Methods of cleaning and inerting the tank;
- f. Name and license number of the DEQ Licensed Service Provider or other person performing cleanup work, and
- g. Name and license number of the DEQ Licensed UST Supervisor or other person supervising cleanup work.

## **GUIDANCE AND REFERENCE DOCUMENTS**

- American National Standards Institute/National Fire Protection Association (ANSI/NFPA), "Flammable and Combustible Liquids Code," Pamphlet #30, 1996. 1-800-344-3555.
- American Petroleum Institute (API) 1604, "Removal and Disposal of Used Underground Petroleum Storage Tanks," March, 1996.
- American Petroleum Institute (API) 2015, "Cleaning Petroleum Storage Tanks," 1994.

*API documents may be purchased from the American Petroleum Institute, at 1-202-682-8000, or viewed at a local library.*

- The National Institute for Occupational Safety and Health (NIOSH) "Criteria for a Recommended Standard. Working in Confined Spaces," Publication #80-106, 1980. 1-800-356-4674.
- Oregon Department of Environmental Quality (DEQ), "Options for Handling Petroleum Contaminated Soil from Underground Storage Tank Cleanup Projects," April, 1993.
- Oregon Department of Environmental Quality (DEQ), "Cleanup Rules for Leaking Petroleum UST Systems," November, 1998.

### **For more information:**

DEQ HOT regulations and guidance documents can be found on the DEQ HOT Program Web Page at <http://www.deq.state.or.us/lq/tanks/hot/index.htm>, or obtained by calling the DEQ UST HELPLINE inside Oregon at 1-800-742-7878 (recorder) or by calling 503-667-8414 ext 55026

## **Appendix 3                    Sampling And Analysis - Excerpts From OAR Chapter 340, Division 122**

The following rules are cited variously throughout this document. For reference purposes only, these rules are reproduced in this guidance document. Some of the requirements of the Heating Oil Tank Generic Remedy may differ from the requirements of the UST Cleanup rules, which were adopted in November, 1998.

### **OAR 340-122-0218                    Sampling and Analysis**

(1) To streamline the investigation of petroleum UST release sites, a responsible person may use expedited site assessment methods (e.g., push probe samplers) for sample collection and analysis as long as all methods and results are documented in subsequent reports to the Department. However, samples used to demonstrate compliance with remediation levels must be collected and analyzed in accordance with this section.

(a) Sample collection, preservation, storage, and handling methods must conform to appropriate procedures in "Test Methods for Evaluating Solid Waste," SW-846, 3rd Edition, Final Updates I, II, IIA, IIB and III, Revised May 1997 (U.S. EPA).

(b) Samples must be tested for all reasonably-likely contaminants of concern relevant to the petroleum released, the age of the release, and the medium contaminated taking into account appropriate remediation levels. The following must be considered and, where appropriate, sampled:

(A) Total Petroleum Hydrocarbons (TPH) in the gasoline range and TPH in the diesel/lube oil range, as appropriate;

(B) For gasoline releases, benzene, toluene, ethylbenzene and total xylenes (BTEX); naphthalene, lead, ethylene dibromide (EDB), ethylene dichloride (EDC), and methyl t-butyl ether (MTBE);

(C) For diesel or heating oil releases, BTEX and polynuclear aromatic hydrocarbons (PAHs); and

(D) For waste oil releases, BTEX, PAHs, volatile chlorinated hydrocarbons, and leachable concentrations of cadmium, chromium, and lead.

(c) Groundwater samples collected for the purpose of testing for lead must be filtered immediately upon collection using a 0.45 micron filter and analyzed for dissolved lead.

(d) The following analytical methods must be employed.

(A) Total Petroleum Hydrocarbons must be analyzed by the Northwest Total Petroleum Hydrocarbon Methods (DEQ, December 1996) including, as appropriate:

(i) Hydrocarbon Identification by NWTPH-HCID;

(ii) Gasoline Range Hydrocarbons by Method NWTPH-Gx; and

(iii) Diesel/Lube Oil Range Hydrocarbons by Method NWTPH-Dx.

(B) Leachable concentrations of cadmium, chromium, and lead must be analyzed by EPA Method 1311 (Toxicity Characteristic Leaching Procedure).

(C) All other contaminants of concern must be analyzed by appropriate procedures described in "Test Methods for Evaluating Solid Waste," SW-846, 3rd Edition, Final Updates I, II, IIA, IIB and III, Revised May 1997 (U.S. EPA).

(e) The Department may accept alternative sampling and analytical methods that have been shown to be appropriate for the contaminants of concern and the media of interest, and that have acceptable quality control measures, and limits of detection.

(2) The Department may request additional tests if site-specific conditions warrant additional information.

## **OAR 340-122-0340            Sample Number and Location**

The collection and analysis of soil samples is required to verify that a site meets the requirements of these rules. These samples must represent the soils remaining at the site and must be collected after contaminated soils have been removed or remediated. Each sample must represent a single location; composite samples are not allowed. The number of soil samples required for a given site and the location at which the samples are to be collected are as follows:

(1) A minimum of two soil samples must be collected from the site:

(a) These samples must be taken from those areas where obviously stained or contaminated soils have been identified and removed or remediated;

(b) If there are two or more distinct areas of soil contamination, then a minimum of one sample must be collected from each of these areas;

(c) The samples must be taken from within the first foot of native soil directly beneath the areas where the contaminated soil has been removed, or from within the area where in-situ remediation has taken place;

(d) A field instrument sensitive to volatile organic compounds may be used to aid in identifying areas that should be sampled, but the field data may not be substituted for laboratory analyses of the soil samples;

(e) If there are no areas of obvious contamination, then samples must be collected from the locations specified in sections (2) - (5) of this rule which are most appropriate for the situation;

(f) If it is being proposed that a pocket of contamination be left in place pursuant to OAR 340-122-0355(4), then sufficient samples must be collected from the site in order to estimate the extent, volume, and level of contamination in this pocket, and the likelihood for the remaining contamination to result in unacceptable risk levels due to volatilization into buildings.

(2) If water is not present in the tank pit:

(a) Soil samples must be collected from the native soils located no more than two feet beneath the tank pit in areas where contamination is most likely to be found;

(b) For the removal of an individual tank, samples must be collected from beneath both ends of the tank. For the removal of multiple tanks from the same pit, a minimum of one sample must be collected for each 150 square feet of area in the pit.

(3) In situations where leaks have been found in the piping, or in which released product has preferentially followed the fill around the piping, samples are to be collected from the native soils directly beneath the areas where obvious contamination has been removed. Samples should be collected at 20 foot intervals.

(4) If water is present in the tank pit, regardless of whether obvious contamination is or is not present, the Department must be notified of this fact. The responsible person shall then either continue the investigation under OAR 340-122-0240, or do the following:

(a) Purge the water from the tank pit and dispose of it in accordance with all currently applicable requirements. This might require obtaining appropriate permits from the Department or local jurisdictions;

(b) If the pit remains dry for 24 hours, testing and cleanup may proceed according to the applicable sections of these soil matrix cleanup rules. If water returns to the pit in less than 24 hours, a determination must be made as to whether contamination is likely to have affected the groundwater outside of the confines of the pit as indicated below:

(A) For the removal of an individual tank, soil samples are to be collected from the walls of the excavation next to the ends of the tank at the original soil/water interface. For the removal of multiple tanks from the same pit, a soil sample is to be collected from each of the four walls of the excavation at the original soil/water interface;

(B) At least one sample must be taken of the water in the pit regardless of whether obvious contamination is or is not present. This sample shall be collected as required by OAR 340-122-0345(4);

(C) The soil samples must be analyzed for TPH and benzene, toluene, ethylbenzene, and xylenes (BTEX). The water sample must be analyzed for BTEX at all sites, and for PAHs where releases of non-gasoline fractions have occurred. Responsible persons may use TPH analyses on groundwater samples as a preliminary screen for PAHs. The TPH method detection limit must be no greater than 0.5 ppm. Any groundwater sample for which TPH is detected must be analyzed for PAHs. These analyses must be made using the methods specified in OAR 340-122-0218. The results of these analyses must be submitted to the Department;

(D) The Department shall then determine how the cleanup shall proceed as specified in OAR 340-122-0355(3).

(5) In situations where tanks, pumps, and lines will remain in place in areas of suspected contamination, the responsible person must submit a specific soil sampling plan to the Department for its approval.

(6) In situations where TPH analysis indicates that contamination is present due to a release from a waste oil tank, at least one sample of the waste oil contaminated soils must be collected and analyzed for volatile chlorinated solvents, volatile aromatic solvents, and leachable metals (Cadmium, Chromium and Lead) using the analytical methods specified in OAR 340-122-0218(1)(c). Analysis for PCBs is also required if the contamination is from a waste oil tank other than one used exclusively for storage of automotive waste oils.

- (1) The following information must be kept during the sampling events:
  - (a) A sketch of the site must be made which clearly shows all of the sample locations and identifies each location with a unique sample identification code;
  - (b) Each soil and water sample must be clearly labeled with its sample identification code. A written record must be maintained which includes, but is not limited to: the date, time and location of the sample collection; the name of the person collecting the sample; how the sample was collected; and any unusual or unexpected problems encountered during the sample collection which may have affected the sample integrity;
  - (c) Formal chain-of-custody records must be maintained for each sample.
- (2) If soil samples cannot be safely collected from the excavation, a backhoe may be used to remove a bucket of native soil from each of the sample areas. The soil is to be brought rapidly to the surface where samples are to be immediately taken from the soil in the bucket.
- (3) The following procedures must be used for the collection of soil samples from open pits or trenches:
  - (a) Just prior to collecting each soil sample, approximately three inches of soil must be rapidly scraped away from the surface of the sample location;
  - (b) To minimize the loss of volatile materials, it is recommended that samples be taken using a driven-tube type sampler. A clean brass or stainless steel tube of at least one inch in diameter and three inches in length may be used for this purpose. The tube should be driven into the soil with a suitable instrument such as a wooden mallet or hammer;
  - (c) The ends of the sample-filled tube must be immediately covered with clean aluminum foil. The foil must be held in place by plastic end caps which are then sealed onto the tube with a suitable tape;
  - (d) Alternatively, samples may be taken with a minimum amount of disturbance and packed immediately in a clean wide-mouth glass jar leaving as little headspace as possible. The jar must then be immediately sealed with a teflon-lined screw cap;
  - (e) After the samples are properly sealed, they are to be immediately placed on ice and maintained at a temperature of no greater than 4 °C (39 °F) until being prepared for analysis by the laboratory. All samples must be analyzed within 14 days of collection.
- (4) The following procedures must be used for the collection of water samples from the tank pit:
  - (a) After the water has been purged from the pit in accordance with OAR 340-122-0340(4)(a), samples shall be collected as soon as sufficient water has returned to the pit to allow representative sampling;
  - (b) Samples are to be taken with a device designed to reduce the loss of volatile components. A bailer with a sampling port is suitable for this purpose;
  - (c) The water is to be transferred into two identical glass vials with as little agitation as possible and immediately sealed with a teflon-lined caps. The vials must be filled completely so that no air bubbles remain trapped inside;

(d) After the samples are properly sealed, they are to be immediately placed on ice and maintained at a temperature of no greater than 4° C (39° F) until being prepared for analysis by the laboratory. All samples must be analyzed within 14 days of collection.

(5) The Department may approve alternative sampling methods which have been clearly shown to be at least as effective with respect to minimizing the loss of volatile materials during sampling and storage as the methods listed in sections (1) - (4) of this rule.

## Appendix 4            Contact Information for DEQ Regional Offices

The following is a list of mailing addresses for each of the regional offices where Underground Storage Tank (UST) staff are located.

The map on the following page shows the areas covered by each region and the contact phone number for each office. In general, ask to speak to the UST Duty Officer or UST staff available.

### EASTERN REGION

DEQ - The Dalles Office  
Columbia Gorge Community College  
400 E. Scenic Dr. Bldg. 2  
The Dalles, OR 97058  
541-298-7255

### NORTHWEST REGION

DEQ - Northwest Region  
2020 SW 4th Ave., #400  
Portland OR 97201  
503-229-5263

DEQ – Gresham Office  
Heating Oil Tank Program  
1550 NW Eastman Parkway, Suite 290  
Gresham, OR 97030  
503-667-8414 ext 55026

**(NOTE: This office handles all HOT sites statewide)**

### WESTERN REGION

DEQ - Eugene Office  
165 East 7<sup>th</sup> Avenue, Suite 120  
Eugene, OR 97401  
541-686-7838

DEQ - Salem Office  
750 Front St NE, #120  
Salem, OR 97301-1039  
503-378-8240

DEQ – Coos Bay Office  
381 N. Second Street  
Coos Bay, OR 97420  
541-269-2721v ext 31

# REGIONAL UST OFFICES

## NORTHWEST REGION

Portland: (503) 229-5263

Gresham: (503) 667-8414 x55026

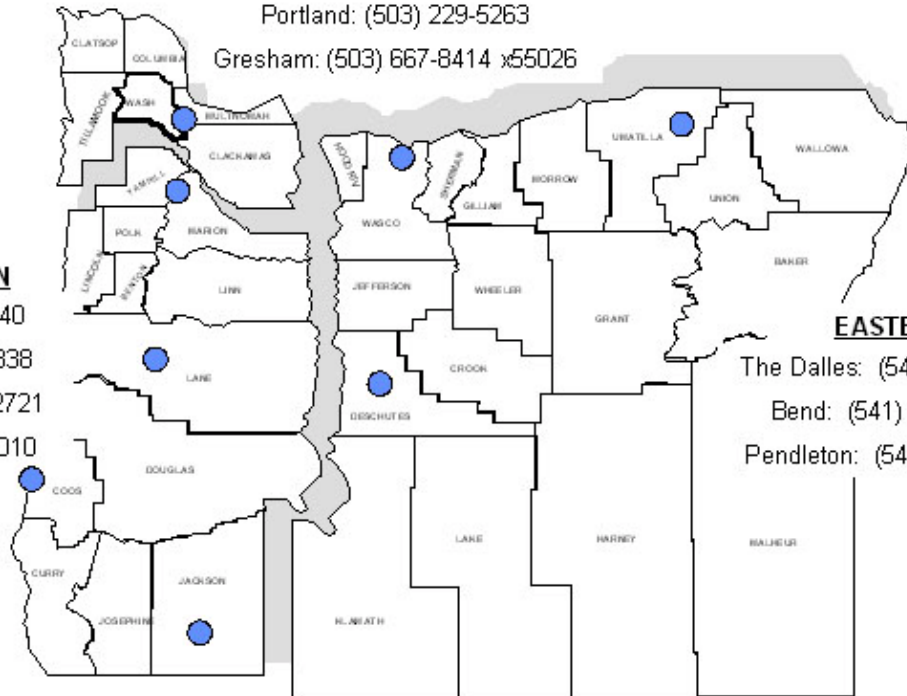

### WESTERN REGION

Salem: (503) 378-8240

Eugene: (541) 686-7838

Coos Bay: (541) 269-2721

Medford: (541) 776-6010

### EASTERN

The Dalles: (541) 298-7255

Bend: (541) 388-6146

Pendleton: (541) 276-4063

- |  |   |  |
|--|---|--|
| UST Program Headquarters:<br>Licensing<br>Portland | (503) 229-6652<br>(503) 229-6652<br>(503) 229-6652<br>(503) 229-6704  | - UST & HOT Service Provider/Supervisor<br>- UST Permits and Fees<br>- UST Permit Modifications (name changes)<br>- Program Policy and Development |
| UST Program Website                                | 1-800-742-7878<br>(503) 229-5733<br><a href="http://www.deq.state.or.us/lq/tanks/ust/index.htm">http://www.deq.state.or.us/lq/tanks/ust/index.htm</a> | - Toll Free recording (Oregon), leave message<br>- Request UST forms, information (recorder)   |
|  | Download forms and guidance, review information on-line   |  |

- |                        |   |   |
|------------------------|---|---|
| HOT Program<br>Gresham | (503) 667-8414 ext 55026  | - Request HOT forms, information                        |
| HOT Program Website    | <a href="http://www.deq.state.or.us/lq/tanks/hot/index.htm">http://www.deq.state.or.us/lq/tanks/hot/index.htm</a> | Download forms and guidance, review information on-line |

Department of Environmental Quality  
Land Quality Division  
Underground Storage Tank Programs  
811 SW Sixth Avenue  
Portland, OR 97204

## **Appendix 5            Blank Forms for Optional Use**

The following pages have not been numbered as part of this manual, but are instead printed so that they may be photocopied directly.

The following eight pages are the instructions and reports for the generic remedy as referenced in Section 5, page 18.

The last two pages are the example calculation diagrams referenced in Section 4.4, pages 14 and 15.



OREGON DEPARTMENT OF ENVIRONMENTAL QUALITY  
Underground Storage Tank Program

HEATING OIL TANK SERVICES  
SERVICE PROVIDER REPORT CERTIFICATION

GENERIC REMEDY HEATING OIL CLEANUP REPORT FORM INSTRUCTIONS

## APPLICABILITY

Before completing the report form, you must first determine if the cleanup project meets the basic qualifying criteria for the Generic Remedy cleanup option.

***Check the box for each of the statements below that are correct.*** If you answer NO to any of these criteria, use of the Heating Oil Tank Generic Remedy is not appropriate. Cleanup must be completed under a different option, such as Soil Matrix or a Corrective Action Plan (Risk-Based Cleanup).

- The release is from an underground residential heating oil tank. (Note: If tank is from a commercial site, you must justify on a second page why the generic remedy is appropriate for this cleanup.)*
- Heating oil (diesel #2) is the source of petroleum contamination (i.e. the tank has not held any other fuel type at any time).*
- Contamination is limited to soil only.*
- No free product is present.*
- After cleanup is complete, the volume of contaminated soil (at or above 500 ppm TPH) allowed to remain in the subsurface is less than 65 cubic yards.*
- Any contaminated soil left in place is deeper than 3 feet below ground surface.*
- Contaminated soil must be above the seasonally high groundwater level.*
- After any soil removal, the maximum Total Petroleum Hydrocarbon (TPH) concentration allowed to remain in subsurface soil is 10,000 ppm or mg/kg.*

If you were able to check each box as “yes”, continue to complete the report. The report form is divided into sections. The instructions are labeled to correspond to each section in the report.

## INSTRUCTIONS

### General Information

The information required in this section is self-explanatory.

- The DEQ Site ID No. is the file or log number assigned by the DEQ NWR Office when the release is reported (by phone or FAX) to DEQ. All correspondence and reports should reference this number to ensure reports are filed with the correct project.
- The square footage of the home is needed to modify calculations in the risk assessment in the event this information is significantly different from original assumptions. The conceptual site model assumes the home is 1200 square feet or larger.

## Initial Abatement Information

**Question #1:** It is important to look for and correct any problems that would result in a further release or spread of heating oil to the environment. Typical “immediate actions” include: pumping the tank to remove any remaining oil, physically removing the tank from the ground, removing any visibly oil saturated soil, and keeping the excavation covered to prevent rain from entering the pit and spreading the contamination any further (i.e. “migration” of the oil contamination).

**Question #2:** Hazards such as fire and explosion as a result of the heating oil release are extremely rare, but could occur if there is free-product present. A hazardous vapor level inside of homes is also a concern if there is extensive heavy contamination under the home without any vapor barriers in place. “Mitigation” generally means that you have checked for and determined that these dangers are not present, or if possible, you have removed the threat by removing the free-product or heavy contamination that is the cause of the threat.

**Question #3:** Self-explanatory. Note the number of gallons of oil removed, or zero if none was present or had been removed at some prior date. Write in the name of the recycling or disposal company where the oil was sent.

**Question #4:** Oil contaminated soil that is left unprotected can cause further hazards when humans are exposed to vapors or contact with skin, or when the soil is exposed to rain and the contamination is spread. These soil piles are often attractive to children. Typical “remedies” include: placing the soil on a tarp or other barrier between the soil and the ground surface, covering the soil with a plastic cover that will not be blown off or easily removed, and securing the area with a fence or other mechanism to prevent persons from coming in contact with the soil. Clean soil should be separated from contaminated soil at all times. If contaminated soil will be taken to a disposal or treatment site, this should be done as soon as possible to eliminate the hazards completely. Contact the DEQ regional office if the contaminated soil must remain on site for more than 30 days.

**Question #5:** Free product is oil that has pooled either in the soil or is visible as a sheen on water in an excavation. Any free product observed must be removed and taken to a treatment or disposal facility. Contact the DEQ regional office if you have questions on how to handle this situation. The observation of free product could be an indicator of serious contamination and use of this Generic Remedy as a cleanup option is not appropriate.

**Question #6:** Water that seeps into the excavation means that groundwater may be impacted. The water must be pumped out of the excavation and taken to a treatment or disposal facility. If the water recharges within 24-hours after pumping, use of this Generic Remedy as a cleanup option is not appropriate. You must notify the DEQ Regional office if groundwater is encountered at any time. If you think that water in the excavation is from rain or another source, you will need to attach additional documentation to show that this site meets generic remedy criteria that contaminated soil will not come in contact with seasonal high groundwater levels.

**Question #7:** Self-explanatory. What action caused the release to be noticed?

**Question #8:** Describe what the tank looked like when it was removed or decommissioned in-place. This gives you valuable information about the source of the release and areas where contamination may be expected to be found. Did you notice any holes or excessive pitting on the exterior or interior that shows where the leak from the tank occurred? Was the tank in very good condition, indicating that the release may be from overfills or spills instead of actual leaks?

**Question #9:** Self-explanatory. Note that contaminated soil cannot remain on-site for more than 30 days without a permit from DEQ. If contaminated soil cannot be removed within 30 days, contact the DEQ for additional information on how to obtain a permit (if a permit is appropriate). Note that local jurisdictions may also have restrictions on storing contaminated soil on site.

**Question #10:** Briefly note any special circumstances or equipment needed for this cleanup project. Were there any difficulties encountered? It is especially important to note anything which could impact sample integrity. Attach a separate page as necessary to describe (or to include information that is typed instead of hand written on this report form).

**Question #11:** Write in the highest value of Total Petroleum Hydrocarbons (TPH) detected. This gives an indication of the seriousness of the release prior to additional excavation and soil removal, or the situation as it was originally encountered without any removal actions.

**Question #12: These attachments labeled A through F are required information.**

Attachment A: This helps give a clear vision to anyone reviewing the report of where areas of potential concern are located.

Attachment B: This is very important information as it lays out visually the horizontal and vertical extent of contamination. The sample identification codes can then be referenced on summaries and can easily be referred to. This shows if contamination has gone under the home, is next to the neighbor's property, and how deep it has gone. Note that when determining the extent and magnitude of contamination, compliance is achieved when TPH-Dx values are shown to have declined to 500 mg/kg.

Attachment C: These are forms used by the analytical laboratory to confirm where samples were taken, when, by whom, etc., and confirms that appropriate sample handling techniques were used.

Attachment D: These are the actual reports provided by the analytical laboratory with sample test results. Summaries are not allowed. The report(s) must show the method reporting limit as well as the test method used. It is critical that the detection limit for benzene be lower than the regulatory limits.

Attachment E: Self-explanatory. Attach a copy of all receipts and other disposal documentation.

Attachment F: Self-explanatory. Attach copies of any pertinent photographs taken during tank decommissioning and cleanup activities. Color photocopies are acceptable.

**Question #13:** The data presented in this summary is extremely important as it provides the quick reference to demonstrate that this site has met compliance requirements. The results reported here are the final sample results - do not include early test results that were taken before excavation (those results will be included in Attachment D). The Sample ID should be easily referenced on Attachment B. Note that if the highest TPH-Dx value after any excavation is over 10,000 mg/kg, this project does not meet the minimum criteria for the generic remedy.

### **Final Report Checklist and Signature**

Checking off each box indicates that the action has been performed correctly and the person who signs the report is verifying that the information is correct. You may need to refer back to the Guidance Document to ensure that each statement is true. The rest of the information required is self-explanatory. Feel free to include any additional information you believe is necessary. Be sure to label any new attachments starting with the letter "G".



OREGON DEPARTMENT OF ENVIRONMENTAL QUALITY
Underground Storage Tank Program

HEATING OIL TANK SERVICES
SERVICE PROVIDER REPORT CERTIFICATION

GENERIC REMEDY HEATING OIL CLEANUP REPORT FORM

Complete this report and submit it to the DEQ NWR Eastside Office (1550 NW Eastman Parkway, Suite 290, Gresham, Oregon, 97030) within sixty (60) days from the date the release from a residential heating oil tank is cleaned up.

General Information

Property Owner Name: DEQ Cleanup File No.:

Property Address:

City/State/Zip Code: County:

Owner Phone Number:

Owner Mailing Address (if different):

Name of Person Reporting Release:

Phone Number (if different from Owner):

Date the release was originally suspected (e.g. water in tank) or confirmed (sight, smell, test).

Date the release was reported to DEQ. Name of DEQ person contacted:

Note: Confirmed releases must be reported within 72-hours by the service provider or the tank owner who performed the work..

Date the tank was removed or decommissioned in-place (circle one).

Approximate size of tank: gallons

If the tank was filled in-place, what type of inert fill material was used?

How much? gallons/lbs.

Date cleanup started.

Date cleanup completed.

Approximate square footage of home on property where the release has occurred.

Initial Abatement Information (circle the appropriate answer)

1. Yes No A visual inspection of the release has been made and immediate actions taken to prevent any further release or migration of heating oil into surrounding soils or groundwater.

2. Yes No Any fire, explosion, and/or vapor hazards in soil or groundwater have been identified and mitigated.
Monitoring for hazards has continued beyond initial identification.

**Initial Abatement Information** (circle the appropriate answer)

3. Yes No NA As much heating oil and sludge as possible has been removed from the tank.  
Gallons removed: \_\_\_\_\_  
Name of oil **recycling** or **disposal** company (circle one): \_\_\_\_\_
4. Yes No Hazards posed by contaminated soil that has been excavated or exposed have been remedied.  
Note: Contaminated soil cannot be stored on-site for more than 30 days without a permit from DEQ.
5. Yes No Free product has been observed in the **tank pit** and/or **groundwater** (circle any that apply).  
Note: Any free product observed must be removed and properly treated/disposed. **Use of the Generic Remedy for Heating Oil Tank Releases is not appropriate if free product is present.**
6. Yes No Groundwater has been encountered during tank decommissioning or cleanup actions taken to-date.  
Note: DEQ must be notified immediately when groundwater is encountered at any time.  
Yes No Water in the tank excavation was encountered and pumped out, but did not recharge after 24 hours.  
**Use of the Generic Remedy for Heating Oil Tank Releases is not appropriate if water recharges into the excavation 24-hours after initial pumping.**

7. How was the release initially discovered? (Check any boxes that are correct)
- During tank decommissioning
  - During a site assessment not associated with tank decommissioning (e.g. for property transaction, etc.)
  - Other. Describe: \_\_\_\_\_

8. What observations were made about the tank condition when it was removed from the excavation or decommissioned in-place? Describe: \_\_\_\_\_
- \_\_\_\_\_
- \_\_\_\_\_

9. How much contaminated soil was removed? \_\_\_\_\_ cubic yards What was done with the contaminated soil?  
(Check any boxes that apply)
- Disposed of at: \_\_\_\_\_ (name of disposal company)
  - Treated off-site at: \_\_\_\_\_ (name of treatment company)
  - Treated on-site. ATTACH copy of Solid Waste Letter of Authorization permit approved by DEQ.  
 Yes  No On-site treatment of contaminated soil is complete.

10. How was the cleanup conducted? Describe actions taken during cleanup and note any unusual circumstances:
- \_\_\_\_\_
- \_\_\_\_\_
- \_\_\_\_\_

11. Note **highest** TPH soil sample result prior to any excavation of soil: \_\_\_\_\_ mg/kg TPH-Dx

12. The following information must be **ATTACHED** as part of this report (clearly label each attachment as listed below):

**Attachment**  
**Label ID**

- A Site map, drawn roughly to scale, showing the location of all buildings on the property and on adjacent properties and the location of the heating oil tank. Include distances in feet between objects.
- B Sketch of the property that clearly shows the sample locations and depths of all soil samples collected and identifies each location and sample with a unique sample identification code. An additional cross-section diagram may be necessary to clearly show sample locations at-depth.
- C Copies of chain-of-custody forms for all soil samples collected.  
Note: Chain-of-custody forms should include the date, time, and location of each sample collected; the name and company of the person collecting the samples; a description of how the samples were collected, stored, and shipped to the laboratory; and note any problems encountered during the cleanup or sampling process that may have affected sample integrity. Forms should clearly state the address of where samples were collected as a unique identifier.
- D Copies of all laboratory data reports. Test methods used, **including method reporting limits**, must be included. Include data for all samples, even if data is not used in summary (question #13).

- E Copies of all receipts or permits related to the disposal of any **oil / sludge, free product, water** pumped from the excavation, contaminated **soil**, and/or decommissioned **tank** and **pipng** (circle all that apply).
- F Any photographs taken at the time of the heating oil tank decommissioning and cleanup that depict major activities (e.g. tank as it is removed to note presence or absence of pits or holes, contaminated soil handling, excavation, tank/excavation in relation to home, unusual circumstances, etc.)

13. Provide a summary of the concentrations measured in the FINAL round of soil samples from each sample location that clearly show the extent and magnitude of the contamination.  
 Note: Write in the specific unit of measurement for each contaminant if different. Write in "N/A" if sample was not analyzed for TPH-Dx concentrations. Use additional pages as necessary to report final summary results.

| Sample ID | Location ID | TPH-Dx Conc. | Benzene Conc. | Ethylbenzene Conc | Naphthalene Conc |
|-----------|-------------|--------------|---------------|-------------------|------------------|
| _____     | _____       | _____ mg/kg  | _____ ppm     | _____ ppm         | _____ ppm        |
| _____     | _____       | _____ mg/kg  | _____ ppm     | _____ ppm         | _____ ppm        |
| _____     | _____       | _____ mg/kg  | _____ ppm     | _____ ppm         | _____ ppm        |
| _____     | _____       | _____ mg/kg  | _____ ppm     | _____ ppm         | _____ ppm        |
| _____     | _____       | _____ mg/kg  | _____ ppm     | _____ ppm         | _____ ppm        |
| _____     | _____       | _____ mg/kg  | _____ ppm     | _____ ppm         | _____ ppm        |

**Final Report Checklist and Signature**

All of the following boxes must be checked indicating that the action has been taken and/or procedures followed correctly. **Completing this information does not substitute for service provider checklist certification requirements in OAR Chapter 340, Division 163.** The person signing this report must ensure that this information is correct. "Guidance" refers to the Heating Oil Tank Generic Remedy Guidance Document.

- The cleanup project is for a release from a residential underground heating oil tank (a tank used primarily for single-family dwelling purposes; OR
- The cleanup project is for a commercial underground heating oil tank. On a separate attachment, describe why use of the generic remedy for residential tanks is appropriate to use for the commercial tank.
- A verbal report of the discovery of contamination from a leaking heating oil tank was made to the appropriate DEQ regional office.
- The underground tank was decommissioned following the procedures in Appendix 2 of the Guidance.
- A site assessment was conducted and the magnitude and extent of the contamination was determined in accordance with the procedures outlined in Appendix 3 of the Guidance.
- All samples were collected in accordance with methods described in OAR 340-122-0345.
- This project meets all of the Qualifying Criteria set forth in Section 2 of the Guidance.
- This project meets Remedial Action Alternative 1 of the Guidance; OR
- This project meets Remedial Action Alternative 2 of the Guidance.

"By my signature below, I state that the information contained in this report is true and complete to the best of my knowledge."

Name of person preparing report: \_\_\_\_\_  Licensed Cleanup Supervisor?  
(please print) (if yes, check box)  
 Signature: \_\_\_\_\_ Date: \_\_\_\_\_  
 Supervisor License No.: \_\_\_\_\_ Expiration Date: \_\_\_\_\_

Licensed Heating Oil Tank  
 Service Provider Company: \_\_\_\_\_

Company License Number: \_\_\_\_\_ Expiration Date: \_\_\_\_\_

Yes  No Additional information is included. If yes, write in attachment label(s): \_\_\_\_\_

**NOTE: If cleanup work and report documentation was conducted by the homeowner, on a separate sheet of paper, describe how you learned how to perform the cleanup work.**

# SAMPLING ALTERNATIVE 1

LESS THAN OR EQUAL  
TO 2,500 PPM

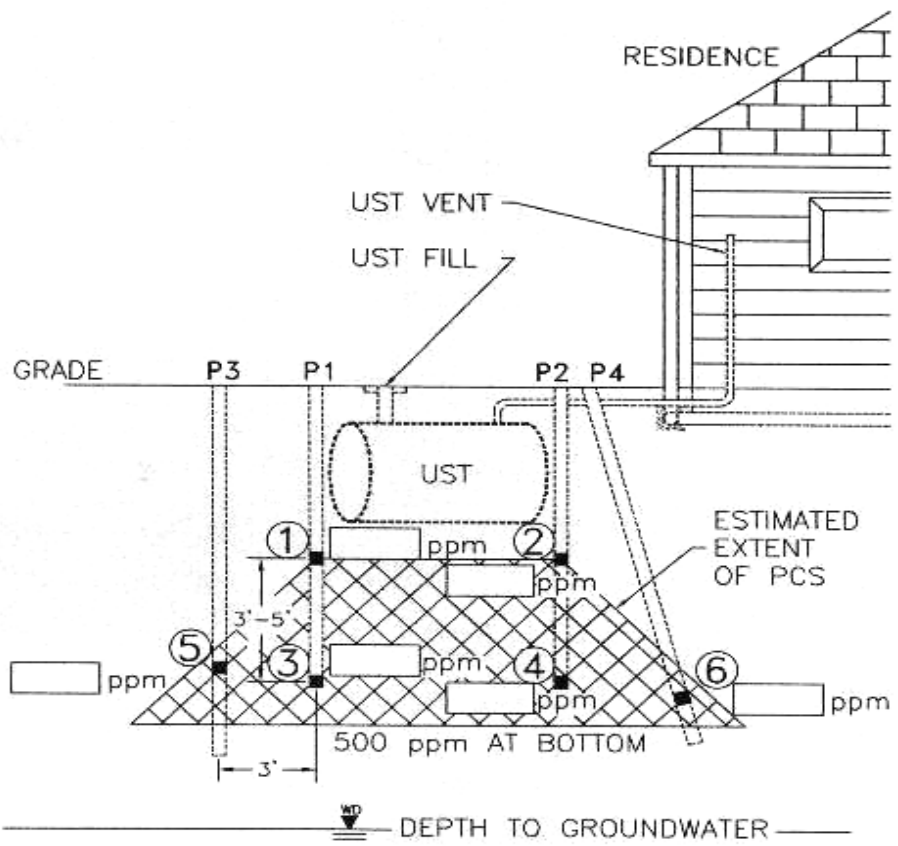

**LEGEND**  
P1 PROBE OR BORING LOCATION, IDENTIFICATION NUMBER, AND SAMPLE LOCATION  
①

## SAMPLING ALTERNATIVE 2

GREATER THAN 2,500 AND  
LESS THAN 10,000

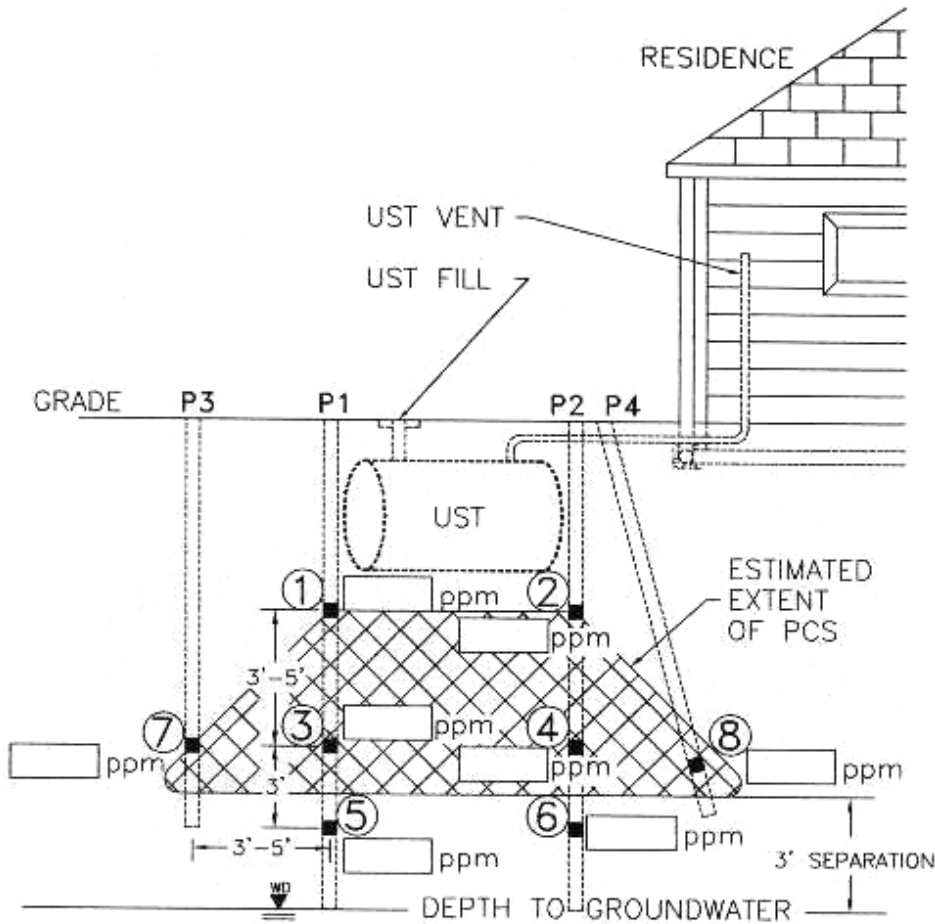

**LEGEND**

- P1 PROBE OR BORING LOCATION, IDENTIFICATION NUMBER, AND
- ① SAMPLE LOCATION