

**SOURCE SAMPLING
MANUAL
VOLUME I**

January, 1976

Revised: April, 1979

August, 1981; January, 1992

**State of Oregon
Department of Environmental Quality
Air Quality Division**

FORWARD

The methods described in this manual are currently being used by the Oregon Department of Environmental Quality and are considered to be the methods on file and approved for demonstration of compliance in accordance with Oregon Administrative Rules, Chapter 340, Section 20-040. These methods have been reviewed and accepted by the Environmental Protection Agency. While it is recognized that these procedures may not be necessarily consistent with other published methods, strict adherence to the enclosed methods is advisable to eliminate the possibility that a test may be rejected by the Department because of the test procedures used.

In the event that a tester prefers to utilize a method other than the one described in this manual, the tester must receive permission from the Department in writing in advance of the test. A copy of the alternate procedure along with the intended application must be forwarded to the Department for review. At its discretion, the Department may require that the equivalency of the alternate method be demonstrated through simultaneous testing or by other means.

Since the state of the art in source sampling is constantly changing, and new or refined methods may be developed, the Department will provide revisions to this manual as they are completed. All users of this manual are encouraged to forward their comments, suggestions, and corrections.

The Source Sampling Manual is in two Volumes. Volume I contains the general source testing requirements and methods for the criteria and hazardous air pollutants. Volume II contains Volatile Organic Compound (VOC) test methods pertaining to gasoline vapor control systems and chemical mass balances.

**Source Sampling Manual
Volume I
Table of Contents**

1.0	INTRODUCTION	1
1.1	Purpose	1
1.2	Applicability	1
1.3	Manual Organization	1
2.0	SOURCE TESTING GENERAL REQUIREMENTS	1
2.1	Department Notification	2
2.2	Source Test Plan	2
2.3	Sample Replicates	3
2.4	Sample time, volumes, and detection limits	4
2.5	Reporting and Record Keeping	4
2.5.1	Reporting	4
2.5.2	Record Keeping	4
3.0	TEST METHODS	5
3.1	Sample locations/Traverse Points	5
3.2	Gas Velocity and Flow Rate	5
3.3	Gas Composition Analysis	5
3.4	Moisture Content of Gas	5
3.4.1	Oregon Method 4 (wet blub/dry bulb)	6
3.5	Particulate Matter	9
3.5.1	Oregon Method 5	10
3.5.2	Oregon Method 7	17
3.5.3	Oregon Method 8	21
3.6	PM ₁₀ Particulate Matter	39
3.7	Sulfur Dioxide	39
3.8	Oxides of Nitrogen	39
3.9	Visible Emissions	39
3.10	Carbon Monoxide	39
3.11	Reduced sulfur	39
3.12	Lead	39
3.13	Fluoride	39
3.14	Volatile Organic Compounds	39
3.15	Polychlorinated Dibenzo-p-Dioxins Polychlorinated Dibenzonfurans	40
3.16	Hydrogen Chloride	40
3.17	Woodstoves	40
4.0	Test Methods for National Emission Standards for Hazardous Air Pollutants (NESHAP)	40
4.1	Mercury	40
4.2	Beryllium	40
4.3	Vinyl Chloride	40
4.4	Arsenic	40

1.0 INTRODUCTION

1.1 Purpose

The purpose of this manual is to identify and describe the source sampling methods on file at the Department of Environmental Quality (DEQ) in accordance with OAR 340-20-040.

1.2 Applicability

The methods identified in this manual are suitable for use in conducting stationary source emissions testing for the purpose of demonstrating compliance (or non-compliance) with Air Contaminant Discharge Permit (ACDP) emission limits. The October, 1991 revision of the Source sampling Manual supersedes all previous versions of this manual.

The methods in this manual are primarily for measuring emissions of the criteria pollutants and some hazardous air pollutants. Methods for other hazardous and toxic air pollutants could be approved on a case-by-case basis at the time of reviewing the source test plan (see section 2). A copy of any method used for DEQ approved source testing shall be retained on file at the Air Quality Division Headquarters

1.3 Manual organization

Section 2 of this manual provides general source testing requirements. Unless otherwise specified in an Oregon Administrative Rule, Air Contaminant Discharge Permit, or DEQ letter, these general requirements shall be followed when conducting source testing in Oregon.

Section 3 lists the specific source sampling methods for criteria pollutants either by reference or described in detail in this manual.

Section 4 lists the specific source sampling methods for hazardous air pollutants.

Many of the U.S. Environmental Protection Agency (EPA) reference source sampling methods have been included by reference because they are identical to Oregon's methods and there is no need for redundancy which could lead to confusion and inconsistency. Copies of these methods can be obtained from government bookstores, the DEQ, or directly from EPA. All methods included in this manual by reference are on file at the DEQ. The EPA methods are incorporated by reference as found in 40 CFR Part 51 Appendix M, 40 CFR Part 60 Appendix A, and 40 CFR Part 61 Appendix B, published on July 1, 1991.

2.0 SOURCE TESTING GENERAL REQUIREMENTS

2.1 Department Notification

The DEQ Source Testing Coordinator shall be notified -of all compliance source tests at least 15 days in advance of the source test date. The notification should be in writing and accompanied by a source test plan.

2.2 Source Test Plan

A source test plan must be approved by the Department in advance of all compliance source testing. As stated above, the DEQ should be provided at least 15 days to review and approve source test plans. In more complex source testing programs, it may be necessary to allow up to 30 days to receive DEQ approval. The source test plan may be generated by the source testing consultant, source operator, or the DEQ. The source test plan will be reviewed by the DEQ Source Testing Coordinator.

A source test plan shall include, as a minimum, the following information:

1. Source Name and address.
2. Source site personnel: contact name and phone number.
3. Source testing personnel: company, contact name, and phone number.
4. Scheduled date of the source test
5. Source Description including a description of the pollution control device and sample locations.
6. Pollutant to be measured.
7. Test Methods
8. Number of sampling replicates
9. Applicable process/production information to be collected during the source test.
10. Control device operating parameters to be monitored during the testing.
11. Fuel samples and type of analysis: who will collect them and who will perform the analysis.
12. Visible emissions measurements: who will take opacity readings during the source test and are they certified.
13. other sampling considerations.
14. Other process considerations.
15. The source test plan shall include the following statements unless otherwise specified by an ACDP condition or DEQ letter:
 - a. It is assumed today, but it will be confirmed on or before the test day, that the duct air flow measuring meets criteria in EPA Methods 1 and 2.

- b. In no case will sampling replicate(s) be accepted if separated by a time duration of twenty-four (24) or more hours, unless prior authorization is granted by the Department.
- c. The source to be tested must operate at a normal production rate during testing. Rates not in agreement with those stipulated in the Air Contaminant Discharge Permit can result in test rejection for application to determine compliance. Imposed process limitations could also result from atypical rates.
- d. The Department must be notified of any changes in source test plans prior to testing. Significant changes not acknowledged by the Department which could affect accuracy and reliability of results could result in test report rejection.
- e. Method-specific quality assurance/quality control (QA/QC) procedures must be performed to ensure that the data is valid for determining source compliance. Documentation of the procedures and results shall be presented in the source test report for review. Omission of this critical information may result in rejection of the data, requiring a retest.
- f. Source test reports must be submitted to the Department within thirty (30) days of the test dates, unless another deadline has been stipulated, either by permit condition, or by Department letter approval.
- g. Two (2) copies of the completed source test report must be sent to the Department; one (1) to the DEQ Regional Operations staff person responsible for the source and the second copy to the Source-Testing Coordinator, Department of Environmental Quality Headquarters in Portland, OR.

2.3 Sample Replicates

Unless otherwise specified by the ACDP or Department letter, a compliance source test shall consist of a minimum of three (3) individual tests with the pollutant emissions determined from the arithmetic average of the three tests. Pollutant emissions may be determined from the arithmetic average of two tests in the event that one of the samples was lost or unusual operating conditions (upset conditions) occurred during the testing.

2.4 Sample time, volumes, and detection limits

In general, compliance source tests shall be a minimum of one (1) hour long and the sample volume shall be sufficient to ensure a minimum detection limit of one half of the emission limit.

For particulate emissions testing, the gravimetric analytical procedure minimum detection limit is considered to be 20 mg (100 mg for high volume samplers) per sample. For Methods 5, 7, and 17, the minimum sample volume shall be the greater of 31.8 dry standard cubic feet (dscf) or 20 mg divided by one half of the emission standard converted to mg/dscf. Sample times shall be a minimum of 60 minutes and a maximum of 480 minutes (8 hours). For Oregon Method 8 (high volume sampler), the minimum sample volume shall be the greater of 150 dry standard cubic feet (dscf) or 100 mg divided by one half of the emission standard converted to mg/dscf. Sample times shall be a minimum of 15 minutes and a maximum of 60 minutes.

2.5 Reporting and Record Keeping

2.5.1 Reporting

Unless otherwise specified by the ACDP, OARs, or DEQ letter, source test reports shall be submitted to the Department within 30 days following the source tests. Each source test report shall include as a minimum the following information:

- a. Name and location of the source.
- b. Date and time of individual tests.
- c. Description of the process, including:
 1. manufacturer and maximum capacity of the process
 2. technology type
 3. pollution control devices.
- d. Production rates during the testing.
- e. Fuel characteristics (if applicable).
- f. Visible emissions (if applicable).
- g. Pollutants
- h. Test Methods
- i. Source sampling equipment
- j. Method-specific equipment calibration data and results.
- k. Field data sheets
- l. Laboratory data sheets

- m. Calculated results
- n. Example calculations;
- o. Discussion of testing and/or process problems encountered during the testing.

2.5.2 Record Keeping

The following records shall be maintained for a minimum of one year:

- a. Equipment calibrations
- b. Analytical results

Unused portions of the source test samples shall be preserved and archived for a minimum of 6 months.

3.0 TEST METHODS

3.1 Sample locations/Traverse Points

EPA Method 1 (40 CFR Part 60 Appendix A, 7-1-91 edition) is incorporated by reference.

3.2 Gas Velocity and Flow rate

EPA Methods 2, 2A, 2B, 2C, and 2D (40 CFR Part 60 Appendix A, 7-1-91 edition) are incorporated by reference.

3.3 Gas composition Analysis

EPA Methods 3 and 3A (40 CFR Part 60 Appendix A, 7-1-91 edition) are incorporated by reference.

3.4 EPA Methods 3 and 3A (40 CFR Part 60 Appendix A, 7-1-91 edition) are incorporated by reference.

Moisture Content of Gas

EPA Method 4 (40 CFR Part 60 Appendix A, 7-1-91 edition) is incorporated by reference.

3.4.1 Oregon Method 4 (wet bulb/dry bulb)

**State of Oregon
Department of Environmental Quality
Source Sampling Method 4**

**Determination of Moisture Content of Stack Gases
(Alternate Method)**

1. **Principle.** The water vapor in a non-saturated gas stream causes a depression of the wet bulb temperature which is proportional to the fraction of moisture present.
2. **Procedure.**
 - 2.1 Measure the dry bulb temperature in the conventional way using either a thermometer or thermocouple.
 - 2.2 Wrap the end of the temperature-measuring device in a cloth sock with water. Insert the sock and temperature-measuring device into the flowing gas stream and allow the temperature to reach a steady state. Caution: after the water on the sock has evaporated, the temperature will rise to the dry bulb temperature. (Figure 4-1). The wet bulb temperature must be taken while the sock is saturated with moisture.
 - 2.3 Apply the wet bulb and dry bulb readings to the appropriate graph (Figure 4-2, 4-3, or 4-4) and determine the approximate water vapor content if the barometric pressure is near 29.92 inches of mercury (in. Hg).
 - 2.4 Alternately, apply the wet bulb and dry bulb readings to equation 4-1 in figure 4-5.
3. **Interference**
 - 3.1 The following conditions may drastically change the wet bulb reading causing erroneous results:
 - 3.1.1 The presence of acid gases in the gas stream, i.e. SO_2 , SO_3 , HCl .
 - 3.1.2 The presence of hydrocarbons in the gas
 - 3.1.3 Marked differences from atmospheric pressure (29.9 in. Hg) of the gas stream (if the graphs are used) .

3.2 Should any of the above interferences be present, the tester should consider another approach to determining moisture content.

3.3 Additionally, the following conditions can lead to difficulties:

3.3.1 Very high dry bulb temperature (in excess of 500° F).

3.3.2 Very high or very low gas velocities.

3.3.3 High concentrations of particulate matter which may adhere to the wet sock.

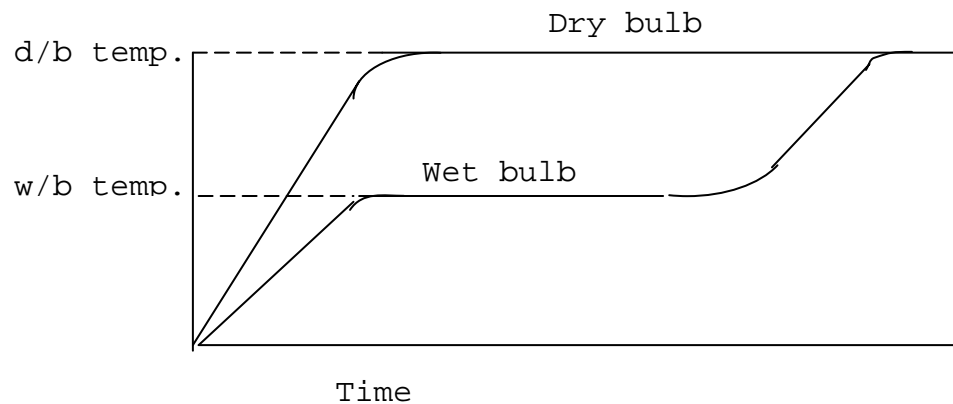

Figure 4-1

3.4 Moisture Equation:

$$\% \text{ H}_2\text{O} = \frac{e'' - \frac{(P_a - e'')(t_d - t_w)}{2800 - [1.3t_w]}}{P_a} \times 100 \quad (4-1)$$

where:

e'' = Vapor pressure of H_2O @ t_w , in. Hg (See Figure 4-5)

P_a = Absolute barometric pressure, in. Hg

t_d = Dry bulb temperature, °F

t_w = Wet bulb temperature, °F

VAPOR PRESSURE OF WATER AT SATURATION*
 (Inches of Mercury)

Temp. Deg. F	0	1	2	3	4	5	6	7	8	9
-20	.0126	.0119	.0112	.0106	.0100	.0095	.0089	.0084	.0080	.0075
-10	.0222	.0209	.0199	.0187	.0176	.0168	.0158	.015	.0142	.0134
-0	.0376	.0359	.0339	.0324	.0306	.0289	.0275	.0259	.0247	.0233
0	.0376	.0398	.0417	.0441	.0463	.0489	.0517	.0541	.0571	.0598
10	.0631	.0660	.0696	.0728	.0768	.0810	.0846	.0892	.0932	.0982
20	.1025	.108	.1127	.1186	.1248	.1302	.1370	.1429	.1502	.1567
30	.1647	.1716	.1803	.1878	.1955	.2035	.2118	.2203	.2292	.2383
40	.2478	.2576	.2677	.2782	.2891	.3004	.3120	.3240	.3364	.3493
50	.3626	.3764	.3906	.4052	.4203	.4359	.4520	.4586	.4858	.5035
60	.5218	.5407	.5601	.5802	.6009	.6222	.6442	.6669	.6903	.7144
70	.7392	.7648	.7912	.8183	.8462	.8750	.9046	~.9352	.9666	.9989
80	1.032	1.066	1.102	1.138	1.175	1.213	1.253	1.293	1.335	1.378
90	1.422	1.467	1.513	1.561	1.610	1.660	1.712	1.765	1.819	1.875
100	1.932	1.992	2.052	2.114	2.178	2.243	2.310	2.379	2.449	2.521
110	2.596	2.672	2.749	2.829	2.911	2.995	3.081	3.169	3.259	3.351
120	3.446	3.543	3.642	3.744	3.848	3.954	4.063	4.174	4.289	4.406
130	4.525	4.647	4.772	4.900	5.031	5.165	5.302	5.442	5.585	5.732
140	5.881	6.034	6.190	6.350	6.513	6.680	6.850	7.024	7.202	7.384
150	7.569	7.759	7.952	8.150	8.351	8.557	8.767	8.981	9.200	9.424
160	9.652	9.885	10.12	10.36	10.61	10.86	11.12	11.38	11.65	11.92
170	12.20	1t.48	12.77	13.07	13.37	13.67	13.98	14.30	14.62	14.96
180	15.29	15.63	15.98	16.34	16.70	17.07	17.44	17.82	18.21	18.61
190	19.01	19.42	19-84	20.27	20.7	21.14	21.5	22.05	22.52	22.99
200	23.47	23.96	24.46	24.97	25.48	26.00	26.53	27.07	27.62	28.18
210	28.75	29.33	29.92	301.52	31.13	31.75	32.38	33.02	33.67	34.33
220	35.00	35.68	36.37	37.07	37.78	38.50	39.24	39.99	40.75	41.52
230	42.31	43.11	43-92	44.74	45.57	46.41	47.27	48.18	49.03	49.93
240	50.84	51.76	52.70	53.65	54.62	55.60	56.60	57.61	58.63	59.67

* Methods for Determination of Velocity, Volume, Dust, and Mist Content of Gases, Bulletin WP-50, Western Precipitation Corp., Los Angeles, Calif., Figure 4-5

The following equation can be substituted for the above table for determining vapor pressures (e") from measured wet bulb (t_w) temperatures:

$$e'' = 6.08764 \times 10^{-6} * t_w^3 - 1.00431 \times 10^{-3} * t_w^2 + 0.0756026 * t_w - 1.69343$$

3.5 Particulate Matter

EPA Methods 5, 5A, 5B, 5D, 5E, 5F, 5G, 5H, and 17 (40 CFR Part 60 Appendix A, 7-1-91 edition) are incorporated by reference for measuring particulate emissions from specific sources as required in Oregon Administrative Rules, Air Contaminant Discharge Permits, and 40 CFR Part 60 regulations.

3.5.1 Oregon Method 5

State of Oregon
Department of Environmental Quality
Source Sampling Method 5

Sampling Particulate Emissions From Stationary Sources

1. Principle and Applicability

1.1 **Principle.** Particulate matter including condensable gases are withdrawn isokinetically from a flowing gas stream. The particulate matter is determined gravimetrically after removal of combined water.

1.2 **Applicability.** This method is applicable to the determination of particulate emissions from stationary sources except those sources for which specified sampling methods have been devised and are on file with the Department.

2. **Acceptability.** Results of this method will be accepted as demonstration of compliance (or non-compliance) provided that the methods included or referenced in this procedure are strictly adhered to and a report containing at least the minimum amount of information regarding the source is included as described in Section 2.5.1. Deviations from the procedures described herein will be permitted only if permission from the Department is obtained in writing in advance of the tests. EPA Method 5 combined with EPA Method 202 may be substituted for this method.

3. Apparatus

3.1 **Sampling Train:** Same as EPA Method 5 Sections 2.1.1 to 2.1.10 with the following exception:

3.1.1 The condenser shall consist of four impingers as described in EPA Method 5 Section 2.1.7.

3.2 **Sample Recovery:** Same as EPA Method 5 Sections 2.2.1 to 2.2.8.

3.3 **Analysis:** Same as EPA Method 5 Sections 2.3.1 to 2.3.7 with the following addition:

3.3.1 Glass separatory funnel (500-1000 ml) with Teflon stopcock and plug.

4. Reagents

- 4.1 Sampling: Same as EPA Method 5 Sections 3.1.1 to 3.1.5 with the following condition:
- 4.1.1 Distilled water with a residue content of less than 0.001% (0.01mg/ml) shall be used in the impingers.
- 4.2 Sample Recovery: Same as EPA Method 5 Section 3.2.
- 4.3 **Analysis:** Same as EPA Method 5 Section 3.3 with following addition:
- 4.3.1 Methylene Chloride (dichloromethane) reagent grade, with a maximum total residue content of 0.001% (0.013 mg/ml).

5. Procedure

- 5.1 Sampling: Same as EPA Method 5 Section 4.1
- 5.2 Sample Recovery: Same as EPA Method 5 Section 4.2 with the following additions:
- 5.2.1 The contents of the impingers, excluding the silica gel impinger, shall be transferred to container No. 4 along with a distilled water rinse of the impingers and interconnects from the back filter holder to the silica gel impinger.
- 5.2.2 Rinse all sample exposed glassware between the filter (excluding the glass frit filter support) and the fourth impinger with acetone and store in container No. 5.
- 5.3 Analysis: Same as EPA Method 5 Section 4.3 with following additions:
- 5.3.1 Transfer the contents of container No. 4 to a separator funnel (Teflon¹ stoppered). Rinse the container with distilled water and add to the separatory funnel.

¹ Mention of trade names or specific products does not constitute endorsement by the Department of Environmental Quality.

Add 50 ml of methylene chloride, stopper, and vigorously shake the separatory funnel 1 minute, let separate and transfer the methylene chloride (lower layer) into a tared beaker or evaporating dish. Repeat twice more.

NOTE: Always leave a small amount of methylene chloride in the separatory funnel to ensure that water does not get into the extracted sample. If water is present in the extracted sample, it will be difficult to completely evaporate the sample to dryness for gravimetric analysis.

5.3.2 Transfer the remaining water in the separator funnel to a tared beaker or evaporating dish and evaporate at 105°C. Desiccate for 24 hours and weigh to a constant weight.

5.3.3 Evaporate the combined impinger water extracts from section 5.3.1 at laboratory temperature ($\leq 70^{\circ}\text{F}$) and pressure, desiccate for 24 hours and weigh to a constant weight.

5.3.4 Transfer the contents of container No. 5 to a tared beaker or evaporating dish, evaporate at laboratory temperature and pressure, desiccate for 24 hours, and weigh to a constant weight.

5.3.5 Evaporate a portion of the solvents in a manner similar to the sample evaporation to determine the solvent blanks.

5.4 Quality Control Procedures: Same as EPA Method 5 Section 4.4.

6. Calibration

6.1 Same as EPA Method 5 Section 5 with the following addition:

6.1.1 The calibration data and/or calibration curves shall be included in the source test report.

7. Calculations

Same as EPA Method 5 Section 6 with the following changes:

7.1 Additions to EPA Method 5 Section 6.1 nomenclature:

C_m = Methylene chloride blank residue concentration,

mg/g.

m_m = Mass of residue of methylene chloride after evaporation, mg.

V_m = Volume of methylene chloride blank, ml.

V_{mw} = Volume of methylene chloride used for Extracting the impinger water, ml.

W_m = Weight of residue in methylene chloride, mg.

P_m = Density of methylene chloride, mg/ml (see label on bottle).

7.2 Add Section 6.6a: Methylene Chloride Blank Concentration:

$$C_m = \frac{m_m}{V_m P_m}$$

7.3 Add Section 6.7a: Methylene Chloride Wash Blank.

$$W_m = C_m V_{mw} P_m$$

7.4 Change Section 6.8 to read:

Total Particulate Weight. Determine the total particulate matter catch from the sum of the weights obtained from Containers 1, 2, 4, 5, and the methylene chloride extract of the water from container 4 less the acetone or methylene chloride blanks (see attached figure 5.3a).

8. **Alternative Procedures, Bibliography, Sampling Train Schematic, Example Data Sheets, Etc.:**

Same as EPA Method 5 Sections 7, 8 and figures 5.1 through 5.12, excluding figure 5.3 (use 5.3a in place of 5.3).

Figure 5.3a - page 1
METHOD 5 DATA ANALYSIS FORM

Plant _____ Run Number _____
 Sample Location _____ Test Date _____
 Sample Recovered by _____

Front Half:	Date/Time	Weight(g)	Audit*	T-°F	RH-%	By
<u>Filter</u>						
Filter ID _____						
Tare Wt _____						
Date/time into Desiccator _____						
<u>Acetone</u>						
Beaker ID _____						
Tare Wt _____						
Solv Vol _____						
Solv ID _____						
Date/time into Desiccator _____						
Back Half:						
<u>Acetone</u>						
Beaker ID _____						
Tare Wt _____						
Solv Vol _____						
Solv ID _____						
Date/time into Desiccator _____						
<u>Water</u>						
Beaker ID _____						
Tare Wt _____						
Solv Vol _____						
Solv ID _____						
Date/time into desiccator _____						
<u>DCM Extract</u>						
Beaker ID _____						
Tare Wt _____						
Solv Vol _____						
Solv ID _____						
Date/time into Desiccator _____						

* filter: 0.5000 g ± tolerance - NIST traceable Class S weight
 beaker: 100.0000 g ± tolerance - NIST traceable Class S weight

Figure 5.3a - page 2
METHOD 5 BLANK ANALYSIS DATA FORM

Sample Prepared by _____ Date _____

Front Half:	Date/Time	Weight(g)	Audit*	T-°F	RH-%	By
<u>Filter</u>						
Filter ID _____						
Tare Wt _____						
Date/time into Desiccator _____						
<u>Acetone</u>						
Beaker ID _____						
Tare Wt _____						
Solv Vol _____						
Solv ID _____						
Date/time into Desiccator _____						
<u>Water</u>						
Beaker ID _____						
Tare Wt _____						
Solv Vol _____						
Solv ID _____						
Date/time into Desiccator _____						
<u>DCM Extract</u>						
Beaker ID _____						
Tare Wt _____						
Solv Vol _____						
Solv ID _____						
Date/time into Desiccator _____						

* filter: 0.5000 g ± tolerance - NIST traceable Class S weight
 beaker: 100.0000 g ± tolerance - NIST traceable Class S weight

3.5.2 Oregon Method 7

State of Oregon
Department of Environmental Quality
Source Sampling Method 7

Sampling Condensable Emissions From Stationary Sources

1. Principle and Applicability

- 1.1 Principle: Particulate matter including condensable gases is withdrawn isokinetically from a flowing gas stream. The particulate matter is determined gravimetrically after extraction with an organic solvent and evaporation.
- 1.2 Applicability: This method is applicable to stationary sources whose primary emissions are condensable gases. It should be considered a modification of Source Sampling Method 5, and applied only when directed to do so by the Department.

2. Sampling Apparatus (Figure 7.1)

- 2.1 Sampling train: Same as Oregon Source Sampling Method 5 Section 3.1 with the following exceptions:
- 2.1.1 The heated filter and cyclone are optional, but should be used if a significant quantity of solid particulate matter is present.
- 1.1.2 An unheated glass fiber filter is placed between the third and fourth impingers.
- 1.2 Sample Recovery and Analysis: Same as Oregon Source Sampling Method 5 Section 3.2 and 3.3.

2. Reagents

Same as Oregon Source Sampling Method 5 Section 4.1 - 4.3.

3. Procedure

- 3.1 Sampling: Same as Oregon Source Sampling Method 5 Section 5.1 with the following addition:
- 4.1.1 Insert numbered and pre-weighted filters into each

of the front (if used) and rear filter holders.

4.2 Sample Recovery: Same as Oregon Source Sampling Method 5 Section 5.2 with the following addition:

4.2.1 Transfer the rear filter to container No. 6.

4.3 Sample Analysis: Same as Oregon Source Sampling Method 5 Section 5.3 with the following addition:

4.3.1 Desiccate the rear filter in container No. 6 for 24 hours at 70°F or less. Weigh the filter to a constant weight.

Note: In some cases, desiccation may give rise to a slow vaporization of the condensable material. Therefore, it is not recommended that an attempt to weigh to constant weight be made. If the weights continue to decrease over time and the sample is obviously dry, use the average of the first three weights to determine the particulate matter catch.

4. Calibrations

4.1 Same as Oregon Source Sampling Method 5 Section 6.

5. Calculations

5.1 Same as Oregon Source Sampling Method 5 Section 7 with the following exception:

6.1.1 Section 7.4 shall be changed as follows:

Total Particulate Weight. Determine the total particulate matter catch from the sum of the weights obtained from Containers 1 (optional), 2,4,5 6, and the methylene chloride extract of the water from Container 4, less the acetone or methylene chloride blanks (see attached Figure 7.2).

6. Alternative Procedures and Example Data Sheets:

Same as Oregon Source Sampling Method 5 Section 8 (Figure 7.2 replaces Figure 5.3a).

Figure 7.1
Method 7 Particulate/Condensibles Sampling Train

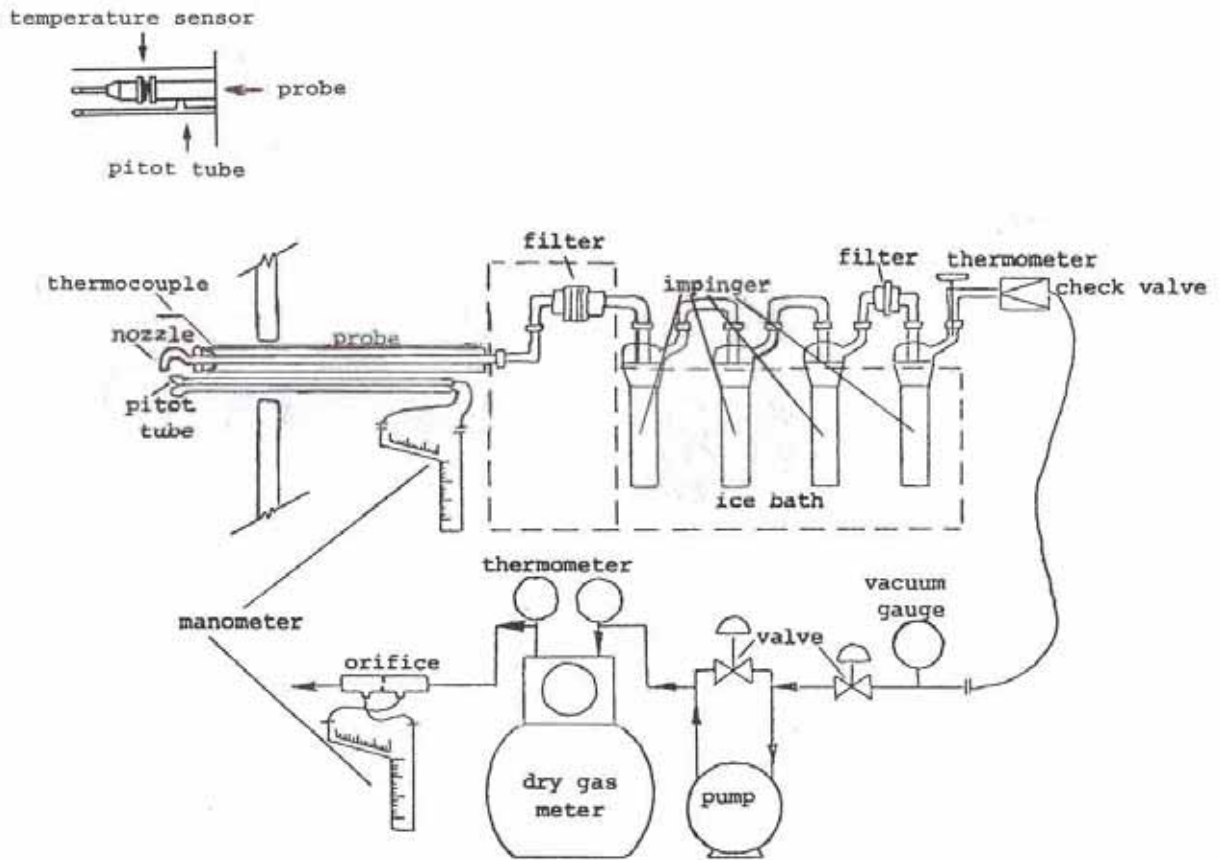

Figure 7-1

Figure 7.2 - page 1
METHOD 7 DATA ANALYSIS FORM

Plant _____ Run Number _____
 Sample Location _____ Test Date _____
 Sample Recovered by _____

Front Half:	Date/Time	Weight (g)	Audit*	T- °F	RH-%	By
<u>Filter</u>						
Filter ID _____						
Tare Wt _____						
Date/time into desiccator _____						
<u>Acetone</u>						
Beaker ID _____						
Tare Wt _____						
Solv Vol _____						
Solv ID _____						
Date/time into desiccator _____						
Back Half:						
<u>Filter</u>						
Filter ID _____						
Tare Wt _____						
Date/time into desiccator _____						
<u>Acetone</u>						
Beaker ID _____						
Tare Wt _____						
Solv Vol _____						
Solv ID _____						
Date/time into desiccator _____						
<u>Water</u>						
Beaker ID _____						
Tare Wt _____						
Solv Vol _____						
Solv ID _____						
Date/time into desiccator _____						
<u>DCM Extract</u>						
Beaker ID _____						
Tare Wt _____						
Solv Vol _____						
Solv ID _____						
Date/time into desiccator _____						

* filter: 0.5000 g tolerance - NIST traceable Class S weight
 beaker: 100.0000 g tolerance - NIST traceable Class S weight

3.5.3 Oregon Method 8

State of Oregon
Department of Environmental Quality
Source Sampling Method 8

Sampling Particulate Emissions From Stationary Sources
(High Volume Method)

1. Principle and Applicability

- 1.1 Principle: Particulate matter is withdrawn isokinetically from a flowing gas stream and deposited on a glass fiber filter. The particulate matter is determined gravimetrically after removal of uncombined water.
- 1.2 Applicability: This method is applicable to stationary sources whose primary emissions are solid particulate. Its primary application is intended to be wood product handling cyclone and baghouse exhaust systems. Prior approval of the Department is required before this method can be applied to other types of source emissions for the purpose of demonstrating compliance.

2 Acceptability

- 2.1 Results from this method will be accepted as a demonstration of compliance (or non-compliance) provided that the methods included or referenced in this procedure are strictly adhered to and a report containing at least the minimum amount of information regarding the source is included. Deviations from the procedures described herein will be permitted only if permission from the Department is obtained in writing in advance of the tests.

3. Sampling Apparatus (Figure 8.1)

- 3.1 Nozzle - smooth metal construction with sharp leading edge. The nozzle shall be connected to the probe by means of a joint designed to minimize particulate matter deposition.
- 3.2 Probe - smooth metal construction. The probe shall be attached to the nozzle and filter holder with air-tight joints designed to minimize particulate matter deposition. The probe should be as short as possible.

- 3.3 Filter holder - air-tight with support screen for the filter.
- 3.4 Metering system - a calibrated orifice followed by a thermometer or thermocouple and flow control device. The metering system shall be connected to the filter holder by means of an air-tight joint.
- 3.5 Pitot tube - P-type or S-type or equivalent, calibrated as described in EPA Method 2 (40 CFR part 60 Appendix A).
- 3.6 Blower - high capacity (typically 60 cfm free air). The blower may be connected to the metering system by a flexible hose if desired.
- 3.7 Probe Brush - flexible, nylon bristle brush at least as long as the probe and nozzle.
- 3.8 Differential Pressure Gauges - liquid manometer, Magnehelicle², or equivalent. Differential pressure gauges other than liquid manometers shall be calibrated against a liquid manometer.
- 3.9 Barometer - mercury, aneroid, or other type capable of measuring atmospheric pressure to within 0.1 in Hg. If the barometric pressure is obtained from a nearby weather bureau station, the true station pressure (not corrected for elevation) must be obtained and an adjustment for elevation differences between the station and sampling site must be applied.
- 3.10 Temperature Gauges - as described in EPA Method 2.
- 3.11 Timer - integrating type, accurate and readable to the nearest 5 seconds per hour.
- 3.12 Filter Storage Container - clean manila envelopes and tagboards, or suitable equivalent.
- 3.13 Sample Storage Containers - glass with leak-tight cap that is resistant to attack by the solvent used, and allows complete recovery of particulate matter. Polyethylene bottles are also acceptable.

²Mention of trade names or specific products does not constitute endorsement by the Department of Environmental Quality.

4. Reagents

- 4.1 Filters - glass fiber filters, free of pinhole leaks or other imperfections and exhibiting at least 99.95% efficiency on 0.3 micron DOP smoke particles. Desiccate individually numbered filters for 24-hours and weigh to the nearest 0.5 mg before use.
- 4.2 Probe Wash Solvent - acetone, reagent-grade, with 0.001% (0.008 mg/ml) residue. For aluminum probes and nozzles, methanol may be substituted for acetone. The same purity is required.

5. Sample Train Preparation

- 5.1 All parts of the sampling train shall be cleaned and properly calibrated as directed in Section 10.
- 5.2 Place a filter in the filter holder with the coarse side facing the flow, being careful not to damage it. Be certain that the filter is positioned so that no air can be drawn around the filter.
- 5.3 Assemble the sample train with the appropriate nozzle and length of probe. Perform a leak check by plugging the nozzle, turning on the blower, and observing the deflection of the flow orifice pressure gauge. The acceptable leakage rate shall not exceed 5% of the expected sample flow rate.

6. Sample Collection

- 6.1 Use a pitot tube to thoroughly map the velocity distribution across the face of the exhaust opening or duct. Areas of zero or negative flow should also be indicated if present. At each point at which the velocity is measured, measure the flow in the direction giving maximum deflection of the pitot pressure gauge. Record the data on Form 3.
- 6.2 Select six or more points of outgoing (positive) flow from the points measured in Section 6.1 to sample. The points shall be representative of the flow pattern, and shall include the point of maximum velocity. If six points of positive flow cannot be obtained, use the maximum number possible. Do not choose any points closer than 2 inches to the exhaust duct wall.

- 6.3 Measure the exhaust temperature.
- 6.4 Determine the nozzle size required for isokinetic sampling. An estimate of the orifice temperature is required. For low temperature exhausts, the orifice temperature is usually very close to the exhaust temperature. For higher temperature exhausts, a trial run may be necessary to determine the expected orifice temperature.
- 6.5 Calculate the required orifice pressure drop for each chosen sampling point to obtain an isokinetic sample rate. With the probe out of the exhaust stream, turn on the blower and adjust the flow rate to that calculated for the first sampling point in Section 6.2. Locate the probe nozzle at the first sampling point, and immediately start the timer. Move the probe around until the velocity pressure matches that for which the sampling flow rate was pre-set. The probe nozzle must be pointing directly into the flow.
- 6.6 Continually monitor the velocity during the sampling period and move the probe around as required to keep it in an area where the velocity matches the original velocity used to calculate the pre-set sampling rate. Record the sampling time, the orifice temperature, and orifice pressure drop on the data sheet. Record data every 5 minutes or once per sampling point, whichever is more frequent. Sample for a length of time so that the total sampling time for all points is at least 15 minutes and a minimum of 100 mg of particulate matter is collected.
- 6.7 Repeat steps 6.5 and 6.6 for each sampling point. The blower need not be turned off between points if readjustments to the new sampling rate can be made rapidly (less than 15 seconds).
- 6.8 Care should be taken so that the nozzle does not touch the walls of the exhaust stack because particulate matter may be dislodged and enter the sample train. If there is reason to believe this has happened, discontinue the sample, clean the train, and restart the test.
- 6.9 If excessive loading of the filter should occur, or the pressure drop should increase such that isokinetic conditions cannot be maintained, replace the filter and continue the test.

- 6.10 At the conclusion of the sampling period, remove the probe from the exhaust and turn off the blower (do not reverse this order because the filter may be broken and sample lost). Plug the nozzle to prevent sample loss, and transport to the sample recovery area.
- 6.11 Conduct a post-test leak check (Section 5.3).
- 6.12 Measure the moisture content, molecular weight, and the barometric pressure (absolute) of the exhaust gas. In most cases, the moisture may be measured by the wet bulb/dry bulb technique as described in Oregon Source Sampling Method 4. The molecular weight shall be measured by EPA Method 3 or 3a. If ambient air is the gas being sampled, the molecular weight can be assumed to equal 29 lbs./lb. mole (29 g/g mole).

7. **Sample Recovery**

- 7.1 Remove the nozzle plug, turn on the blower, insert the probe brush into the nozzle, and brush the particulate from the nozzle and probe onto the filter. Do not insert the brush so far in that it will come into contact with the filter. Turn off the blower.
- 7.2 Open the filter holder and carefully remove the filter. Inspect the filter for holes or tears, or places where the samples are deposited up to the edge of the filter indicating a leak around the filter. If any are found, clean the train and repeat the run. Fold the filter once lengthwise with the dirty side in, and place in a folded manila tagboard, folded edge down. Fasten the outside edge of the tagboard with a paper clip, and place in the manila envelope.
- 7.3 Rinse the inside front of the filter holder, probe, and nozzle with acetone or methanol while brushing. Repeat the rinsing/brushing until all particulate is removed as evidenced by a lack of visible residue on the inside surfaces after evaporation of the acetone or methanol. Retain the acetone or methanol rinse and a blank sample of the acetone or methanol in labeled containers for laboratory analysis.

8. **Analysis**

- 8.1 Desiccate the filter for 24-hours at room temperature (70°F or less), and weigh to a constant weight to the nearest 0.5mg.

NOTE: Make certain that any particulate that may have dislodged from the filter into the tagboard or envelope is returned to the filter before weighing.

NOTE: Since the relatively large filter and particulate catch may be hygroscopic, weigh immediately upon removal from the desiccator.

- 8.2 Blanks shall be run in the field before and after the complete source testing activity. A minimum of 2 blanks shall be collected for each source test. This is accomplished by inserting a pre-weighed filter into the filter holder, performing a leak check, removing the filter, and treating it as a sample filter in accordance with Section 7.2.

- 8.3 Quantitatively transfer the solvent rinse and blank solvent to tared beakers or evaporating dishes, evaporate at room temperature (70°F or less) and pressure, desiccate, and weigh to a constant weight to the nearest 0.5 mg.

- 8.4 Record the data on Form 4.

9. **Exhaust Gas Flow Rate Measurement**

- 9.1 Since the air flow pattern at the location of the sampling points may preclude an accurate flow rate measurement, a point upstream of the sampling point shall be selected for a velocity traverse. The flow rate at the velocity sampling point should accurately represent the flow rate to the atmosphere at the particulate sampling point (i.e., no air flows should be added to or removed from the system between the velocity and the particulate sampling points).

- 9.2 Select a suitable velocity sampling location in accordance with EPA Method 1.

- 9.3 Measure the gas velocity and flow rate in accordance with EPA Method 2.

10. **Calibration**

- 10.1 The orifice flow meter shall be calibrated at least once a year using a primary standard or a device which has been

calibrated against a primary standard. The calibration data and calibration curves for the orifice and intermediate standard shall be included in the source test report, along with documentation of the primary standard.

10.2 The pitot tube, differential pressure gauges, and thermometers or thermocouples, shall be calibrated at least every six months. The calibration data and/or calibration curves shall be included in the source test report.

10.3 The calibration records shall include the date, place, and method of calibration.

11. Calculations

11.1 Total particulate emissions from the system shall be calculated by multiplying the particulate concentration measured at the exhaust by the flow through the system.

11.2 Particulate Concentration: The following calculations shall be conducted for each test run:

11.2.1 Total Sample Weight: Calculate the total sample weight from laboratory results by adding the net weight gain of the filter sample(s), adjusted for a blank value, to the net weight of particulate matter collected in the acetone rinse, corrected for an acetone blank. If the acetone rinse represents more than one test run, the particulate mass should be pro-rated for each test run according to the relative net weights of the particulate matter collected on the filters. Record the results on a laboratory form such as Figure 8.2.

11.2.2 Total Sample Gas Volume: Calculate the sample gas volume for each sample point by multiplying the duration of the sample in minutes, times the average sample flow rate (actual cubic feet per minute - acfm). Add the volume of all sample points to get the total sample gas volume for the test run.

Sample flow rates for each point shall be determined from the orifice calibration curve. Typically, the orifice calibration curve is generated for flows at standard temperature and pressure, using 68°F and 29.92 in. Hg. As standard

conditions. In order to obtain actual flows through the orifice, it is necessary to correct the calibration curve flows for the orifice temperature and pressure.

$$Q_a = Q_s \times \frac{T_o}{598} \times \frac{29.92}{P_o}$$

where,

Q_o = actual flow rate through the orifice, acfm

Q_s = calibration flow rate through the orifice, scfm

T_o = orifice temperature, °F

P_o = orifice pressure, "Hg

- 11.2.3 Calculate the particulate concentration in gr/dscf by the following equation:

$$C_g = 0.0154 \times \frac{m_n}{V_{std}}$$

Where,

C_s = particulate concentration, gr/dscf

m_n = total particulate weight, mg.

V_{std} = total sample volume, dscf.

Bws = fraction moisture content in the sampled gas.

t = sample time, minutes

11.3 Total Exhaust Gas Flow Rate

Use EPA Method 2 calculations to determine the total exhaust gas flow rate using the data obtained from section 9. For some cyclones, the total flow may be adjusted to account for air purposely vented out the bottom of the cyclone.

11.4 Total Emissions

Calculate the total particulate emission rate (lb/hr) by the following equation, using Form 5:

$$E = 2.205E-6 \times \frac{m}{V_{std}} \times Q_{sd}$$

Where;

2.205E-6 = conversion factor, lb/mg

Q_{sd} = Total Exhaust Gas Flow Rate, dscf/hr

11.5 Percent Isokinetic

Use the tabular computing equations in Form 5 to compute the percent isokinetic (I), defined as the ratio of the average velocity of the sample gas entering the sample nozzle to the average local velocity at the sampling points. In order to achieve acceptable results, the value of this parameter must be between 82% and 120%. Test results falling outside this range shall be discarded, and the test repeated.

12. Test Reports

The test report shall include as a minimum the information requested in Section 2.5.1 of this manual.

Figure 8.1 - Typical Hi-Vol Particulate Sampling Train

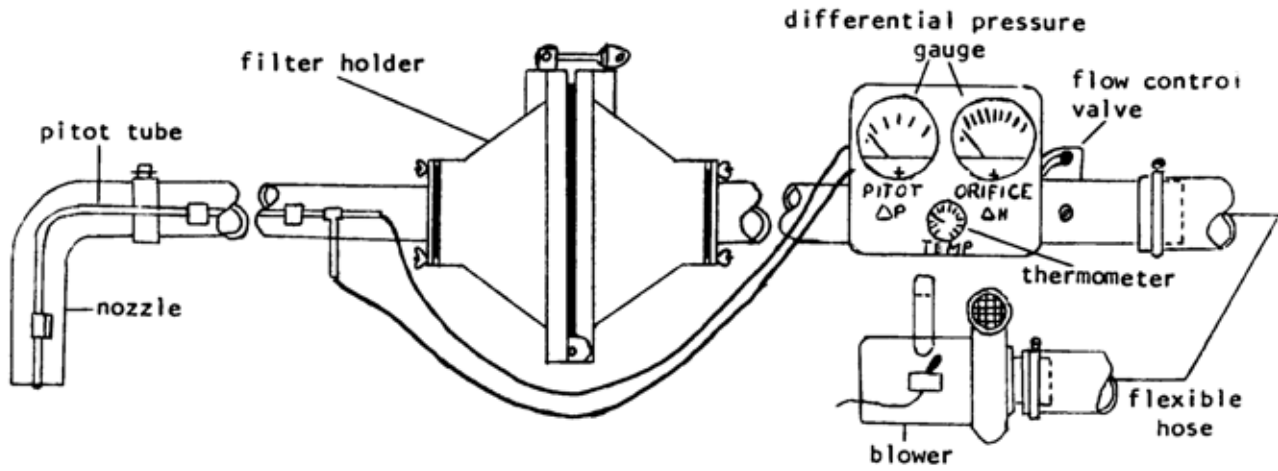

Figure 8-1

Figure 8.2 - page 1
METHOD 8 DATA ANALYSIS FORM

Plant _____ Run Number _____
 Sample Location _____ Test Date _____
 Sample Recovered by _____

	Date/Time	Weight(g)	Audit*	T- °F	RH-%	By
<u>Filter</u>						
Filter ID _____						
Tare Wt _____						
Date/time into desiccator _____						
<u>Acetone</u>						
Beaker ID _____						
Tare Wt _____						
Solv Vol _____						
Solv ID _____						
Date/time into desiccator _____						

* filter: 0.5000 g tolerance - NIST traceable Class S weight
 beaker: 100.0000 g tolerance - NIST traceable Class S weight

METHOD 8 BLANK ANALYSIS DATA FORM

	Date/Time	Weight(g)	Audit*	T- °F	RH-%	By
<u>Filter</u>						
Filter ID _____						
Tare Wt _____						
Date/time into desiccator _____						
<u>Acetone</u>						
Beaker ID _____						
Tare Wt _____						
Solv Vol _____						
Solv ID _____						
Date/time into desiccator _____						

* filter: 0.5000 g tolerance - NIST traceable Class S weight
 beaker: 100.0000 g tolerance - NIST traceable Class S weight

Sampling Data And Field Analysis

Plant Name/Location _____ Source Identification _____

Date _____; Time _____; By(name) _____ Process Operation During Test _____

Temperature: Dry bulb _____ F/ R; Wet bulb _____ F; %Moisture _____; Ambient _____ F

Gas composition: %O₂ _____; %CO₂ _____; Pitot factor (C_p) _____; Static Press (P_g) _____ "H₂O

Nozzle Dia. _____ in.; Nozzle area (A_n) _____ in²; Barometric Pressure(P_b) _____ in. H_g

PT.	Location		Velocity Pressure		Orifice σH		Orifice Temp.(°F)	Sample Time (min.)	Rate at Orifice Temp. (acfm)	Volume at Orifice Temp. (cu.ft.)	Data Summaries and Calculations
	X	Y	σP	4σP	Pre-set In. H ₂ O	Actual in. H ₂ O					
1											T _o = avg. orifice temperature + 460 = °R
2											V _o = total sample volume at orifice temperature = ft ³
3											B _{ws} = fraction moisture content = %moisture/100 =
4											
5											V _{std} = total sample volume at standard conditions = V _o x 528/T _o x P _b /29.92 x (1 - B _{ws}) = dscf
6											
Avg. or Total											
Filter Number									Probe Washings		C _s = particulate concentration = m _n /V _{std} x 0.0154 = gr/dscf
Filter & Sample Weight											
Filter Tare Weight											
Sample Weight											M _n = total mass of particulate matter = mg
Blank Weight											
Sample Adjusted Weight											

EMISSION CALCULATION AND SUMMARY

Plant Name and Location _____

Date _____ By (name) _____

Exhaust Gas Flow Rate Calculations						
σP	Avg. velocity pressure, "H ₂ O	Form 1				
T _s	Avg. stack gas temp., °R	Form 1				
P _b	Barometric pressure, "H _g	Form 1				
P _g	Stack static pressure "H ₂ O	Form 1				
P _s	Stack absolute pressure, "H _g	$P_g/13.6 + P_b$				
B _{ws}	Water vapor in gas stream, proportion by volume	%H ₂ O/100, Form 1				
M _d	Molecular weight of stack gas, dry basis, lb/lb mole	$(0.44 \times \% CO_2) + (0.32 \times \% O_2) + 0.28 \times (100 - \% CO_2 - \% O_2)$				
M _s	Molecular weight of stack gas, wet basis, lb/lb mole	$M_d \times (1 - B_{ws}) + 18 \times B_{ws}$				
K _p	Pitot tube constant	85.49				
V _s	Avg stack gas velocity, ft/sec	$K_p \times C_p \times \text{SQRT} \{ (\sigma P \times T_s) / (M_s \times P_s) \}$				
A	Cross sectional area of stack, ft ²	Form 1				
Q _{sd}	Dry volumetric stack gas flow rate corrected to standard conditions, dscf/hr	$V_s \times (1 - B_{ws}) \times /a \times 528./ T_s \times P_s / 29.92$				

EMISSION CALCULATION AND SUMMARY

Plant Name and Location _____

Date _____ By (name) _____

σP	Avg. velocity pressure at sample point, "H ₂ O	Form 3				
T _s	Avg. stack gas temp. at sample point, °R	Form 3				
P _b	Barometric pressure, "H _g	Form 3				
P _g	Stack static pressure at sample point "H ₂ O	Form 3				
P _s	Stack absolute pressure, "H _g	$P_g/13.6 + P_b$				
B _{ws}	Water vapor in gas stream at sample point, proportion by volume	%H ₂ O/100, Form 3				
M _d	Molecular weight of stack gas at sample point, dry basis, lb/lb mole	$(0.44 \times \% \text{CO}_2) + (0.32 \times \% \text{O}_2) + 0.28 \times (100 - \% \text{CO}_2 - \% \text{O}_2)$				
M _s	Molecular weight of stack gas at sample point, wet basis, lb/lb mole	$M_d \times (1 - B_{ws}) + 18 \times B_{ws}$				
K _p	Pitot tube constant	85.49				
V _s	Avg stack gas velocity, ft/sec	$K_p \times C_p \times \text{SQRT} \{ (\sigma P \times T_s) / (M_s \times P_s) \}$				

EMISSION CALCULATION AND SUMMARY

Plant Name and Location _____

Date _____ By (name) _____

Partiulate Emissions and Sampling Isokinetic Calculations:						
g_o	Avg. sample rate, acfm	Form 3				
t	Total sample time, minutes	Form 3				
V_o	Sample volume @ orifice temperature, acf	$g_o \times t$				
T_o	Avg. orifice temperature, °R	Form 3				
B_{ws}	Water vapor in gas stream at the sample point, proportion by volume	% H ₂ O/100, Form 3				
V_{std}	Sample volume corrected to standard conditions, scf	$V_o \times (1 - B_{ws}) \times 528 / T_o \times P_b / 29.92$				
m_n	Mass of particulate matter collected, mg	Form 3				
C_s	Particulate concentration, gr/dscf	$0.0154 \times m_n / V_{std}$				
E	Particulate emission rate, lb/hr	$m_n / V_{std} \times 2.205E^{-6} \times Q_{sd}$				
A_n	Cross sectional area of the sampling nozzle, in ²	Form 3				
T_s	Avg. temperature of the exhaust gas at the sample point, °R	Form 3				
V_n	Velocity of sample gas through the nozzle, ft/min	$G_o / A_n \times T_s / T_o \times 144$				
V_s	Avg exhaust gas velocity at sample point, ft/min	Form 4, page 2				
I	Percent isokinetic	$100 \times V_n / V_s$				

3.6 PM₁₀ Particulate Matter

EPA Methods 201, 201A, 202 (40 CFR Part 1 Appendix M, 7-1-901 edition) are incorporated by reference.

3.7 Sulfur Dioxide

EPA Methods 6, 6A, 6B, 6C, 8, and 19 (40 CFR Part 60 Appendix A, 7-1-91 edition) are incorporated by reference.

3.8 Oxides of Nitrogen

EPA Methods 7, 7A, 7B, 7C, 7D, 7E, 19 and 20 (40 CFR Part 60 Appendix A, 7-1-91 edition) are incorporated by reference.

3.9 Visible Emissions

EPA Methods 9, Alternate Method 1 (LIDAR), and 22 (40CFR Part 60 Appendix A, 7-1-91 edition) are incorporated by reference.

EPA Method 9 observation periods and data reduction shall be modified to demonstrate compliance with specific Oregon regulations and permit limits.

3.10 Carbon Monoxide

EPA Methods 10, 10A, and 10B (40 CFR Part 60 Appendix A, 7-1-91 edition) are incorporated by reference.

3.11 Reduced Sulfur

EPA Methods 11, 15, 15A, 16, 16A and 16B (40 CFR Part 60 Appendix A, 7-1-91 edition) are incorporated by reference.

3.12 Lead

EPA Method 12 (40 CFR Part 60 Appendix A, 7-1-91 edition) is incorporated by reference.

3.13 Fluoride

EPA Methods 13, 13A, 13B and 14 (40 CFR Part 60 Appendix A, 7-1-91 edition) are incorporated by reference.

3.14 Volatile Organic Compounds

EPA Methods 18, 21, 24, 24A, 25, 25A, and 25B (40 CFR Part 60 Appendix A, 7-1-91 edition) are incorporated by reference. Volume II of the source sampling manual contains VOC methods specific to gasoline vapor control systems and chemical mass balances.

3.15 Polychlorinated Dibenzop-Dioxins Polychlorinated Dibenzofurans

EPA Method 23 (40 CFR Part 60 Appendix A, 7-1-91 edition) is incorporated by reference.

3.16 Hydrogen Chloride

EPA Method 26 (40 CFR Part 60 Appendix A, 7-1-91 edition) is incorporated by reference.

3.17 Woodstoves

EPA Method 28 (40 CFR Part 60 Appendix A, 7-1-91 edition) is incorporated by reference.

4.0 Test Methods for National Emission Standards for Hazardous Air Pollutants (NESHAP)

4.1 Mercury

EPA Methods 101, 101A, 102, and 105 (40 CFR Part 61 Appendix B, 7-1-91 edition) are incorporated by reference.

4.2 Beryllium

EPA Methods 103 and 104 (40 CFR Part 61 Appendix B, 7-1-91 edition) are incorporated by reference.

4.3 Vinyl Chloride

EPA Methods 106, 107, and 107A (40 CFR Part 61 Appendix B, 7-1-91 edition) are incorporated by reference.

4.4 Arsenic

EPA Methods 108, 108A, and 108C (40 CFR Part 61 Appendix B, 7-1-91 edition) are incorporated by reference.